

USER MANUAL

KX80S

CUSTOM  M[®]

CUSTOM S.p.A.
Via Berettine 2/B
43010 Fontevivo (PARMA) - Italy
Tel. : +39 0521-680111
Fax : +39 0521-610701
http: www.custom.biz

Customer Service Department:
www.custom4u.it

© 2024 CUSTOM S.p.A. – Italy.
All rights reserved. Total or partial reproduction of this manual in whatever form, whether by printed or electronic means, is forbidden. While guaranteeing that the information contained in it has been carefully checked, CUSTOM S.p.A. and other entities utilized in the realization of this manual bear no responsibility for how the manual is used. Information regarding any errors found in it or suggestions on how it could be improved are appreciated. Since products are subject to continuous check and improvement, CUSTOM S.p.A. reserves the right to make changes in information contained in this manual without prior notification.

The pre-installed multimedia contents are protected from Copyright CUSTOM S.p.A. Other company and product names mentioned herein may be trademarks of their respective companies. Mention of third-party products is for informational purposes only and constitutes neither an endorsement nor a recommendation. CUSTOM S.p.A. assumes no responsibility with regard to the performance or use of these products.

THE IMAGES USED IN THIS MANUAL ARE USED AS AN ILLUSTRATIVE EXAMPLES. THEY COULDN'T REPRODUCE THE DESCRIBED MODEL FAITHFULLY.

UNLESS OTHERWISE SPECIFIED, THE INFORMATION GIVEN IN THIS MANUAL ARE REFERRED TO ALL MODELS IN PRODUCTION AT THE ISSUE DATE OF THIS DOCUMENT.

GENERAL INSTRUCTIONS

CUSTOM S.p.A. declines all responsibility for accidents or damage to persons or property occurring as a result of tampering, structural or functional modifications, unsuitable or incorrect installations, environments not in keeping with the equipment's protection degree or with the required temperature and humidity conditions, failure to carry out maintenance and periodical inspections and poor repair work.

GENERAL SAFETY INFORMATION

Your attention is drawn to the following actions that could compromise the characteristics of the product:

- Read and retain the instructions which follow.
- Follow all indications and instructions given on the device.
- Make sure that the surface on which the device rests is stable. If it is not, the device could fall, seriously damaging it.
- Make sure that the device rests on a hard (non-padded) surface and that there is sufficient ventilation.
- Do not fix indissolubly the device or its accessories such as power supplies unless specifically provided in this manual.
- When positioning the device, make sure cables do not get damaged.
- [Only OEM equipment] The equipment must be installed in a kiosk or system that provides mechanical, electrical and fire protection.
- The mains power supply must comply with the rules in force in the Country where you intend to install the equipment.
- Make sure that there is an easily-accessible outlet with a capacity of no less than 10A closely to where the device is to be installed.
- Make sure the power cable provided with the appliance, or that you intend to use is suitable with the wall socket available in the system.
- Make sure the electrical system that supplies power to the device is equipped with a ground wire and is protected by a differential switch.
- Before any type of work is done on the machine, disconnect the power supply.
- Use the type of electrical power supply indicated on the device label.
- These devices are intended to be powered by a separately certified power module having an SELV, non-energy hazardous output. (IEC60950-1 second edition).
- [Only POS equipment] The energy to the equipment must be provided by power supply approved by CUSTOM S.p.A.
- Take care the operating temperature range of equipment and its ancillary components.
- Do not block the ventilation openings.
- Do not insert objects inside the device as this could cause short-circuiting or damage components that could jeopardize printer functioning.
- Do not carry out repairs on the device yourself, except for the normal maintenance operations given in the user manual.
- The equipment must be accessible on these components only to trained, authorized personnel.
- Periodically perform scheduled maintenance on the device to avoid dirt build-up that could compromise the correct, safe operation of the unit.
- Do not touch the head heating line with bare hands or metal objects. Do not perform any operation inside the printer immediately after printing because the head and motor tend to become very hot.
- Use consumables approved by CUSTOM S.p.A.



THE CE MARK AFFIXED TO THE PRODUCT CERTIFY THAT THE PRODUCT SATISFIES THE BASIC SAFETY REQUIREMENTS.

The device is in conformity with the essential Electromagnetic Compatibility and Electric Safety requirements laid down in Directives 2014/30/EU and 2014/35/EU inasmuch as it was designed in conformity with the provisions laid down in the following Standards:

- EN 55032 (*Electromagnetic compatibility of multimedia equipment - Emission Requirements*)
- EN 55024/EN55035 (*Electromagnetic compatibility of multimedia equipment - Immunity requirements*)
- EN IEC/EN62368-1 (*Audio/video, information and communication technology equipment*)

The device is in conformity with the essential requirements laid down in Directives 2014/53/EU about devices equipped with intentional radiators. The Declaration of Conformity and other available certifications can be downloaded from the site www.custom4u.it.



GUIDELINES FOR THE DISPOSAL OF THE PRODUCT

The crossed-out rubbish bin logo means that used electrical and electronic products shall NOT be mixed with unsorted municipal waste. For more detailed information about recycling of this product, refer to the instructions of your country for the disposal of these products.

- Do not dispose of this equipment as miscellaneous solid municipal waste, but arrange to have it collected separately.
- The re-use or correct recycling of the electronic and electrical equipment (EEE) is important in order to protect the environment and the wellbeing of humans.
- In accordance with European Directive WEEE 2012/19/EU, special collection points are available to which to deliver waste electrical and electronic equipment and the equipment can also be handed over to a distributor at the moment of purchasing a new equivalent type.
- The public administration and producers of electrical and electronic equipment are involved in facilitating the processes of the re-use and recovery of waste electrical and electronic equipment through the organisation of collection activities and the use of appropriate planning arrangements.
- Unauthorised disposal of waste electrical and electronic equipment is punishable by law with the appropriate penalties.
- For the waste sorting of the packaging materials, please check the local waste disposal laws.



The format used for this manual improves use of natural resources reducing the quantity of necessary paper to print this copy.

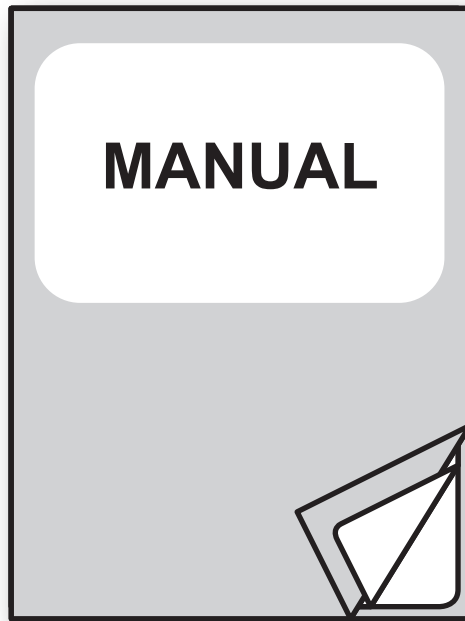

For details on the commands,
refer to the manual with code **0577200M000089**

TABLE OF CONTENTS

1	INTRODUCTION	9
2	PRINTER FEATURES	11
3	MAIN FUNCTIONS.....	13
3.1	Power switch.....	13
3.2	Paper feed button	14
3.3	Status notification indicator.....	15
3.4	Detect sensors	16
3.5	Paper width setting	17
3.6	Black Mark	18
4	PRINTER USE GUIDE.....	21
4.1	Power port connection method	21
4.2	Interface connection	22
4.3	Paper Change	23
4.4	Self-test	26
4.5	HEX dump print	27
5	INSTALLATION.....	29
5.1	Method by making hook shapes on the Top side and mounting the printer	29
5.2	Method by using Mount Brackets for fixing and mounting the printer	30
5.3	Method by mounting in the floor (BOTTOM) side	31
6	PRINTER FUNCTION SETTINGS	33
6.1	Setting manually	33
6.2	Set using memory switch program	35
6.3	Firmware update	37
6.4	Ethernet interface settings	38
6.5	When using in dynamic IP DHCP mode	40
6.6	Ticket paper settings	41

7	INTERFACE SPECIFICATION	43
7.1	RS-232C	43
7.2	USB	44
7.3	ETHERNET	45
8	SPECIFICATIONS	47
8.1	Hardware specifications	47
8.2	External dimensions	49
9	ACCESSORIES	51
10	TECHNICAL SERVICE	53



1 INTRODUCTION

This document is divided into sections and chapters. Each chapter can be reached by the index at the beginning of this document. The index can be reached by the button on each page as shown in the diagram below.

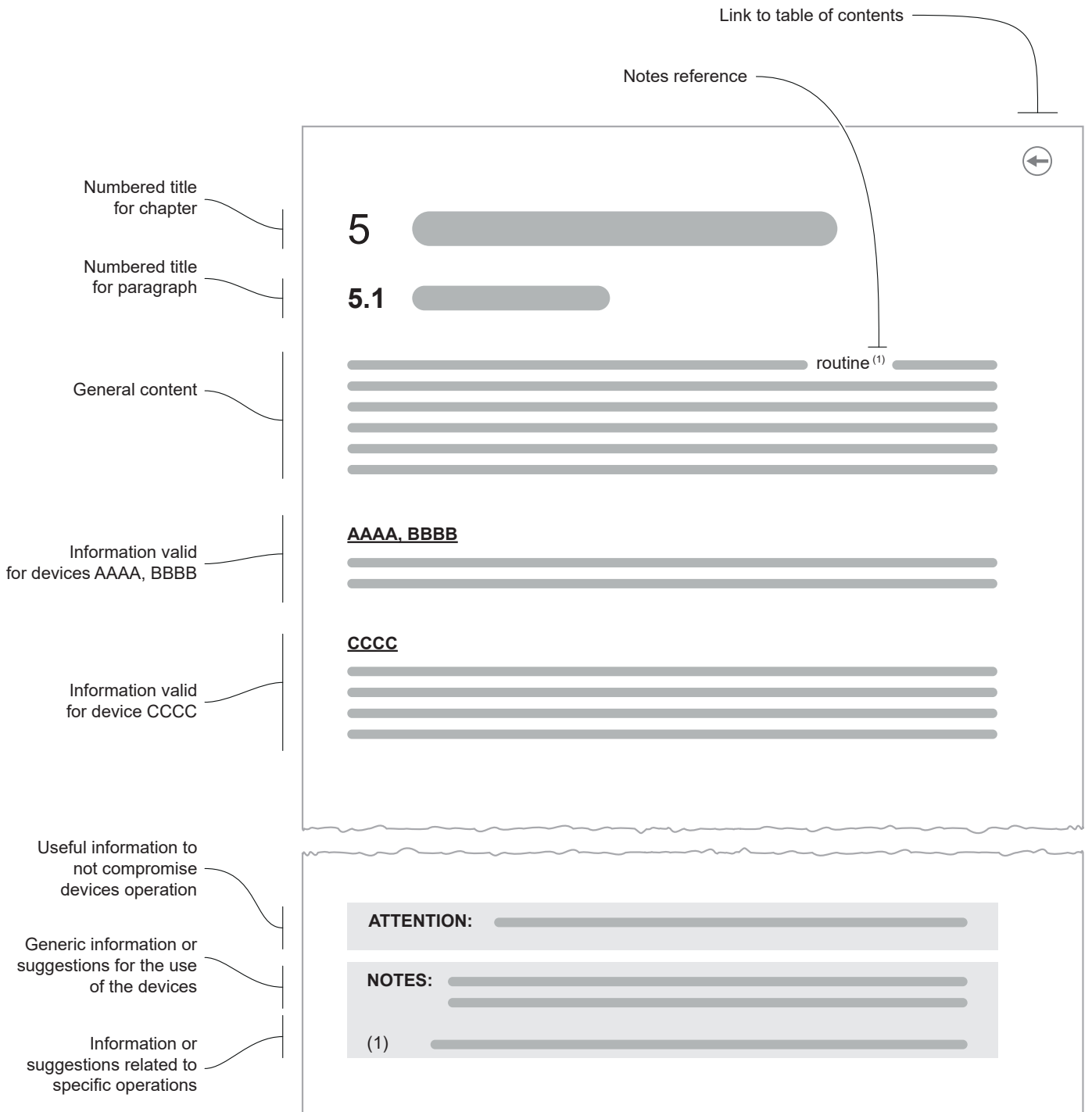





2 PRINTER FEATURES

KX80S series printers are designed to be used by installing or connecting to Kiosk Systems. This printer uses direct thermal printing method and the paper width can be set to suit user's environment. Also, with KX80S Series Printers, both of Roll type paper and Fan Folder type paper can be used.

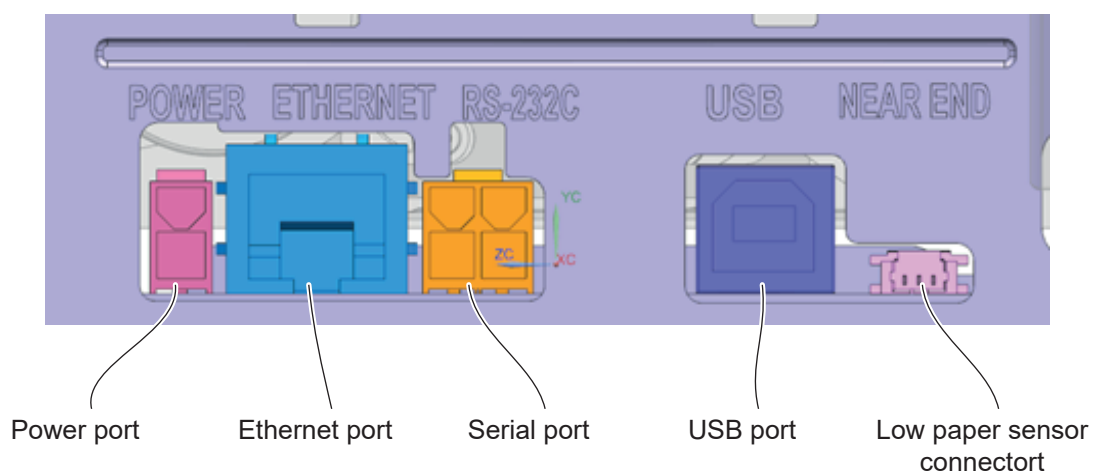
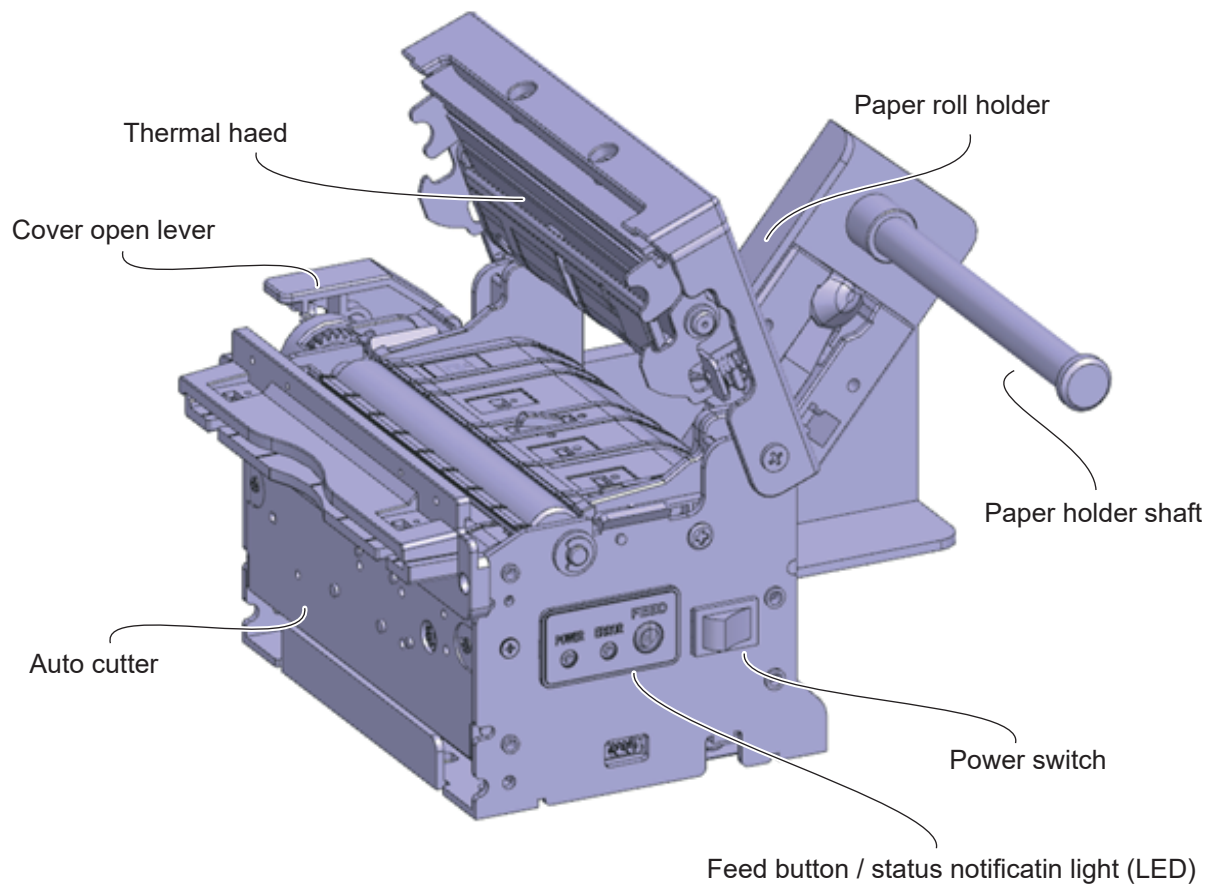





3 MAIN FUNCTIONS

3.1 Power switch

The power switch is used to turn the power on or off, and it is also used for self-test and changing printer status settings.

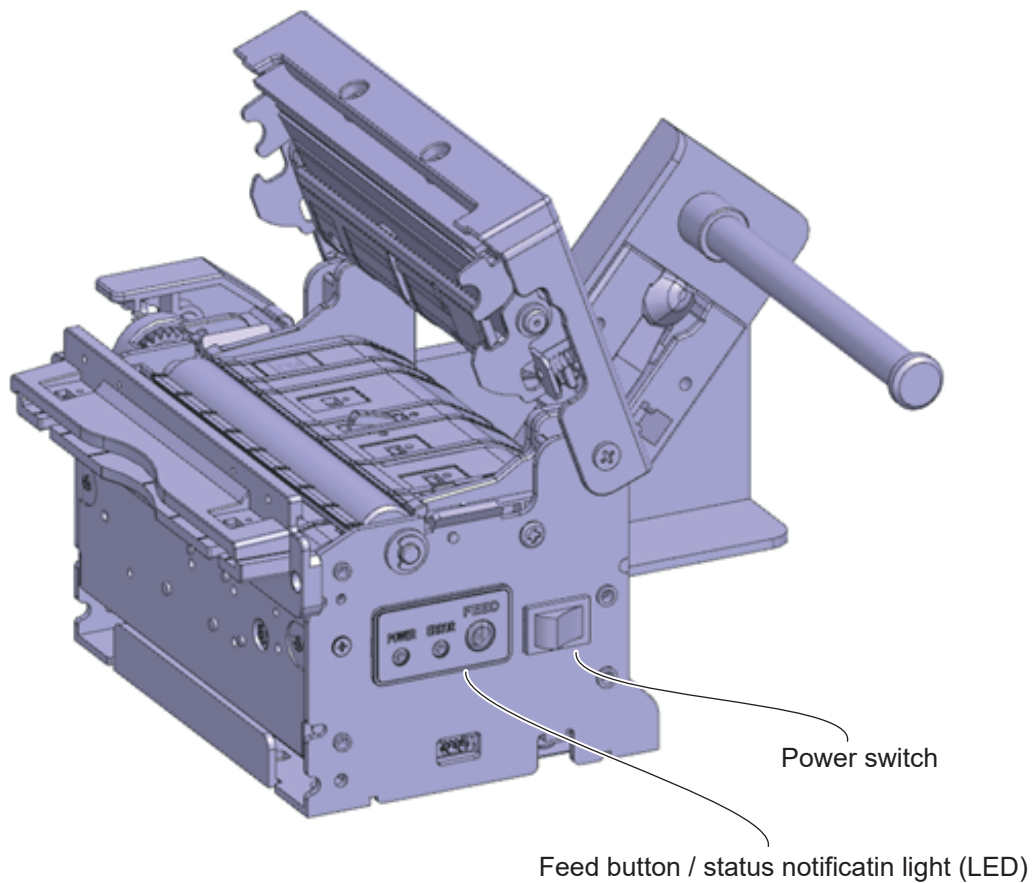

3.2 Paper feed button

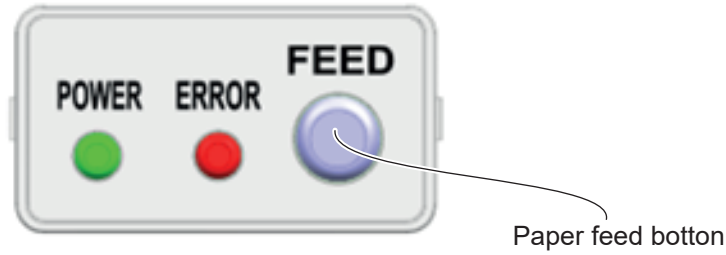

The FEED button can perform the following functions.

- Paper feed: When paper is inserted, pressing the feed button feeds paper for as long as the button is pressed.
- Self Test: While holding the FEED button, turn on the power and then release the button after the Error light turns on once. The self test contents will then be printed. (Refer to the description of the [chapter 4](#)).
- Checking and changing the printer status: If you turn on the power while holding the FEED button, the Error light flashes continuously. When the button is released at this time, the printer status menu is printed. (Refer to the description of the [chapter 6](#)).
-

3.3 Status notification indicator

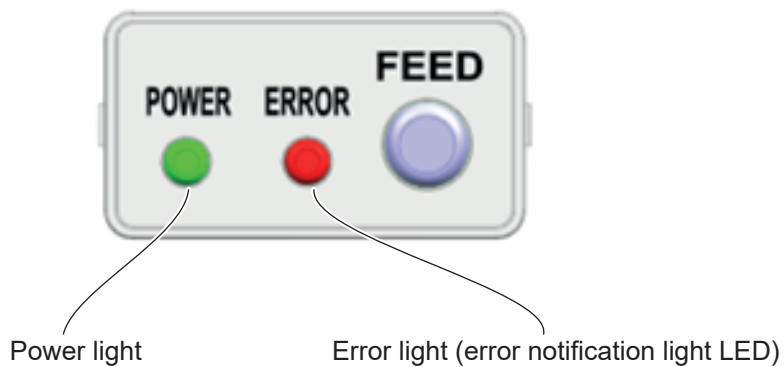

- Power light: When the power is turned on, the green power light turns on.
- Error light: Depending on the printer status, the light blinks to inform you of the printer status as shown below.

NOTIFICATION LIGHT STATUS	NOTIFICATION SOUND	PRINTER STATUS
Flashing briefly	Beep (short)	No paper
Long flashing	Beeeeep (long)	Cover open, cutter jammed, paper jammed, etc.

3.4 Detect sensors

Several detection sensors placed on the printer transmit the printer's status to the host system.

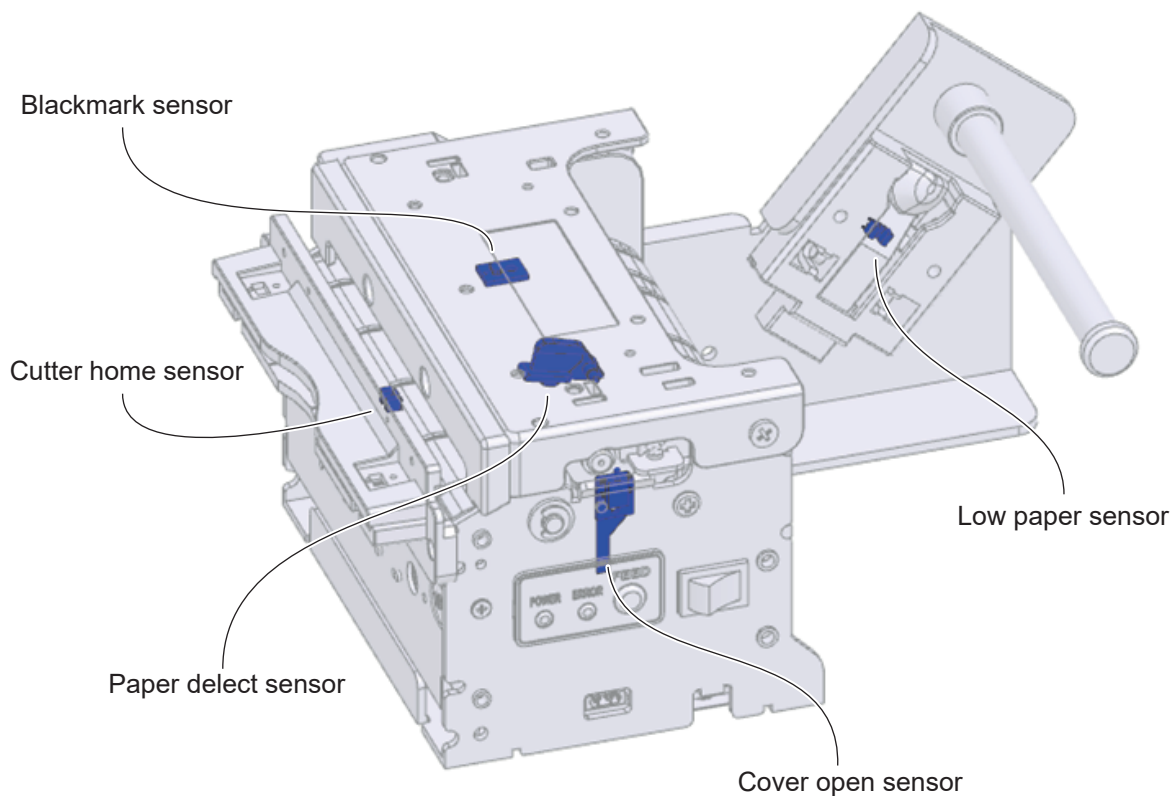

COVER OPEN SENSOR

The cover open switch detects when the cover is open and stops the printing and ticket feeding process until the cover is closed.

PAPER DETECT SENSOR

A sensor that detects the presence and absence of paper, used to control paper insertion and printing, as well as notifications to notify the user to reload paper.

BLACKMARK SENSOR

It is used to control the starting point of printing by detecting the black mark position.

CUTTER HOME SENSOR

The cutter sensor is used to detect if the paper has been cut.

LOW PAPER SENSOR

The Near End (Paper Low) Sensor (Paper shortage detection sensor) is a detection sensor that automatically informs the user when to change paper.



3.5 Paper width setting

The paper fixing guide is fixed during manufacturing in either 80mm. User cannot change it to a different size.

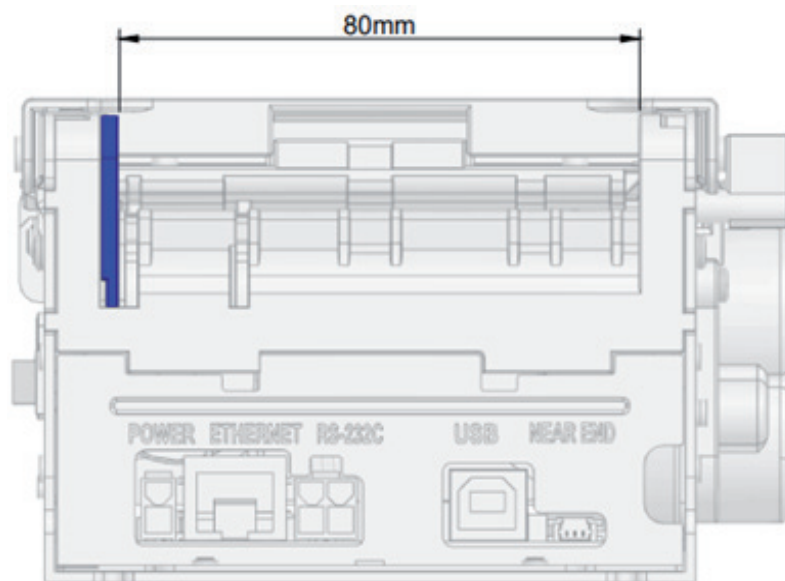

User can adjust the paper width to 82.5mm by removing the paper guide.

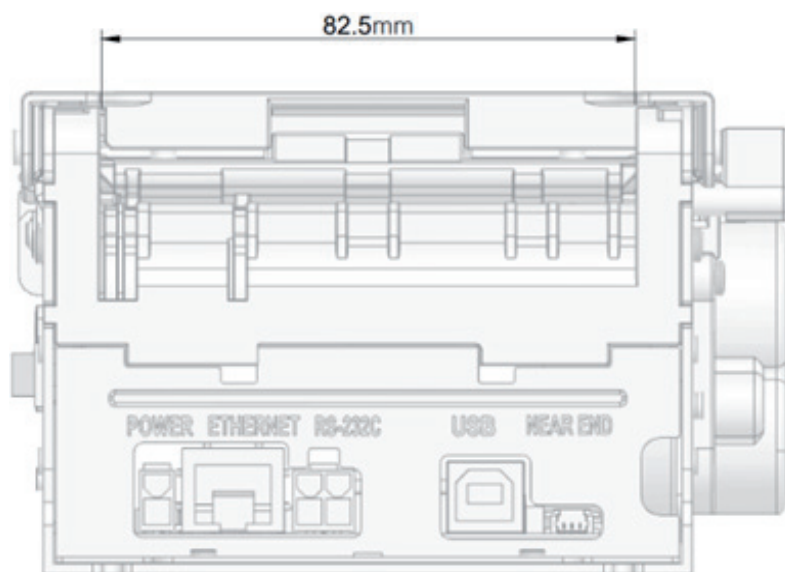



3.6 Black Mark

Black Mark Sensor Location

The position of the black mark sensor is fixed during manufacture. It is not possible for user to change to a different location. It is shipped from the location of the following figure, fixed to the location desired by the user.

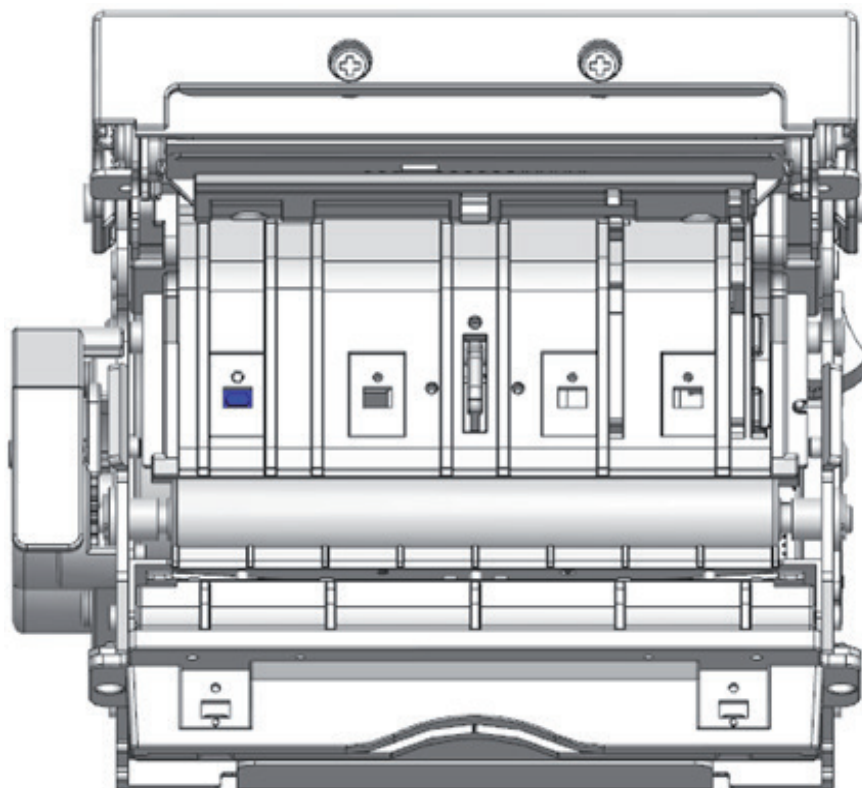

Blackmark Paper Specification

The following illustration shows the minimum size and location of the black mark. Only paper with black marks on non-printed surfaces is available. Blackmark minimum interval values vary when using Presenter and adjustable type.

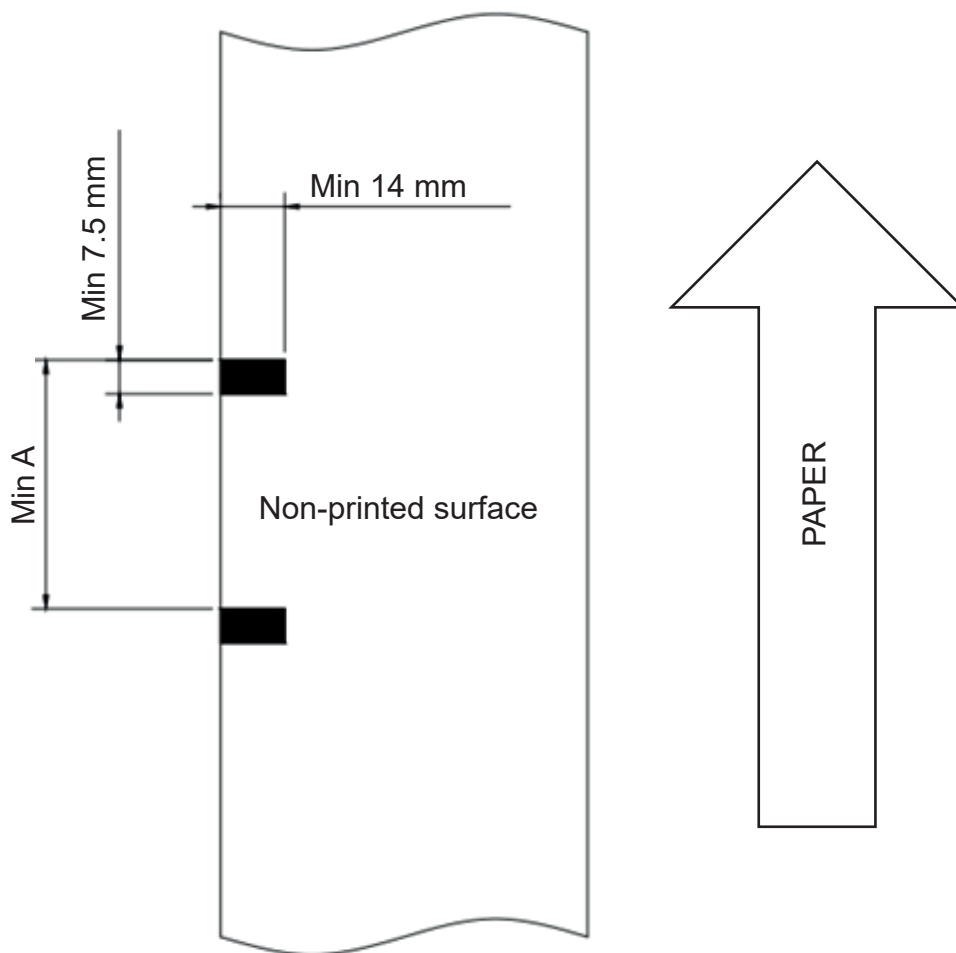



4 PRINTER USE GUIDE

4.1 Power port connection method

When connecting power, be sure to connect the power cable to the power port while the power switch turned off.

- 2 hole power cable connection

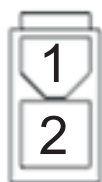
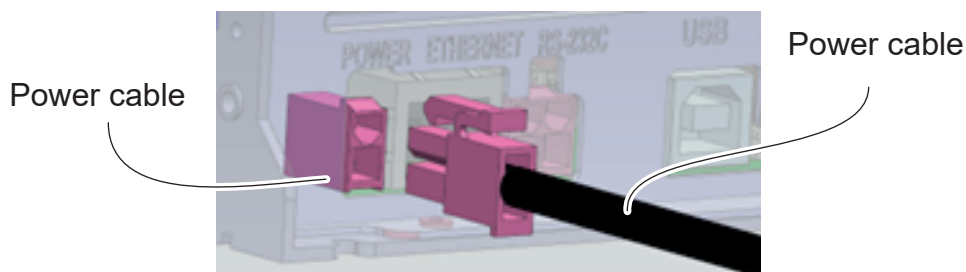

PIN	CONFIGURATION
1	GND
2	+24V DC

ATTENTION: The rated power of this product is 24 V, so do not use a power supply that is out of specification. It may cause product failure or safety accident.

Please use only the power supply provided by our company for the power supply. Be sure to connect according to the instructions in the manual.



4.2 Interface connection

Use an interface cable that meets the specifications of the host.

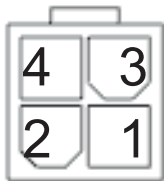
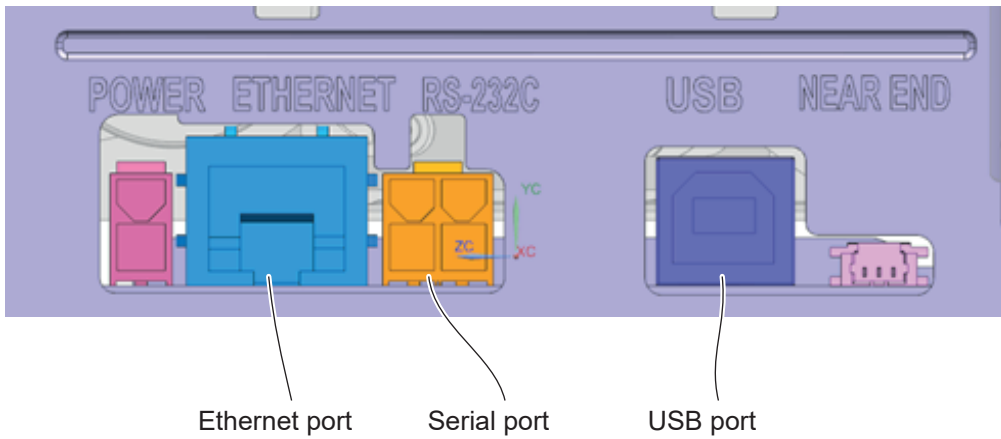

PIN	SIGNA	INPUT OUTPUT
1	TXD	OUTPUT
2	RXD	INPUT
4	GND	-
3	RTS	OUTPUT

ATTENTION: When connecting a communication cable, be sure to that the power switch is turned off.

4.3 Paper Change

Cover open method

- Press the open lever in the direction of the arrow to open the printer cover.

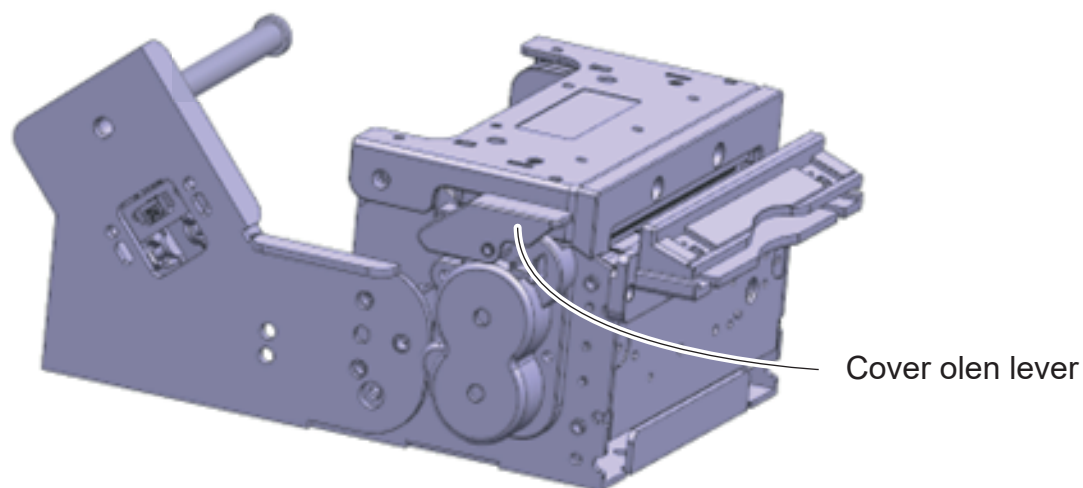

- Insert paper into the opened paper slot. Be careful not to change the side to be printed on the paper at this time.

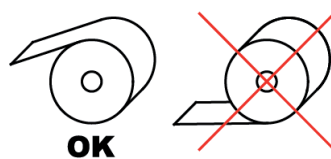

- Insert paper enough so that the end of the paper comes out to the front of the printer's platen roller.

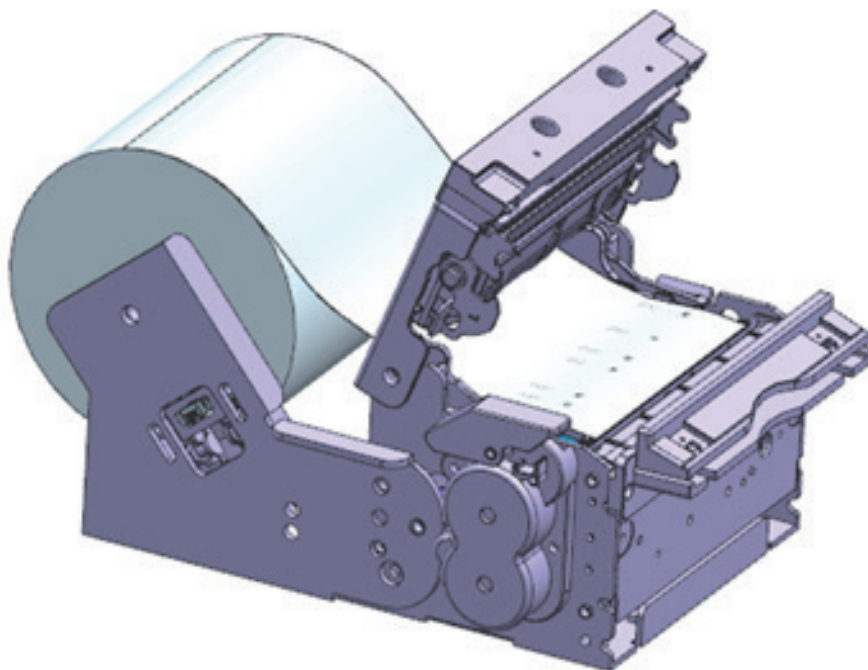

- Close the cover by pressing it in the direction of the arrow.

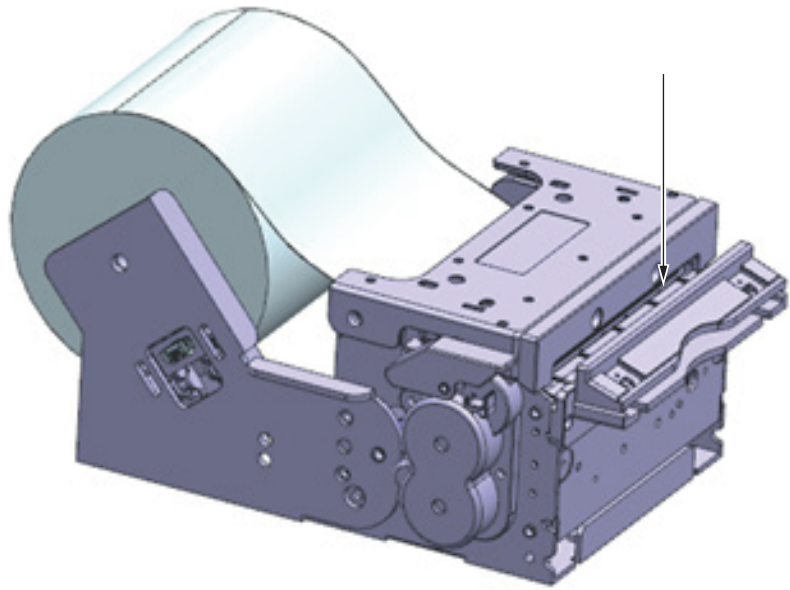

ATTENTION: When closing the cover, be sure to press the middle part of the cover (near the arrow) to close it. Otherwise, blurring of the print, etc. may occur.

Auto Loading Method

- Turn on the Printer's Power

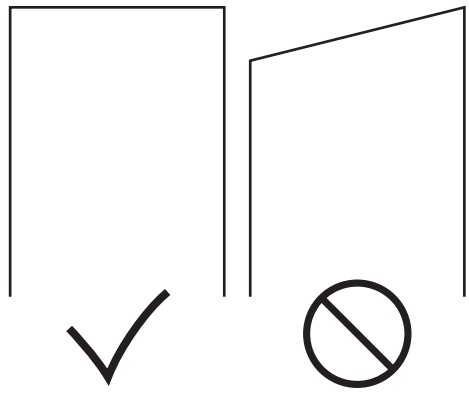

Cut the end of the paper straight as shown below with scissors.

ATTENTION: If the end of the paper is not cut straight as shown in the example, the paper may not be inserted properly or a paper jam may occur.

- When the paper is pushed to the paper detect sensor inside the paper input port with the cover closed, the printer will start the auto loading, and the paper is cut after a certain length is fed.

4.4 Self-test

You can check the current settings of the printer through the self-test.

- With the power off, turn on the printer while pressing down on the feed button.
- If you turn on the power and keep pressing the feed button (about 1second), the red ERROR light flickers, and when you remove the feed button, the printing begins.
- Printing contents are printed as follows.

```
*****  
  
KX80S Control Board  
Firmware      : Ver x.xx  
Create       :20xxxxxx  
*****  
  
Interface and Setting information  
=====
```

Interface	: USB & RS-232C
BaudeRate	: 19200
Data Bit	: 8 Bit
Parity	: None
Stop Bit	: 1 or 2

```
=====
```

Peripheral & Setting information
=====

USB . P



4.5 HEX dump print

Turn the power off and back on after the confirmation of HEX DUMP in Initial Setting Mode. After printing as [HEX DUMP MODE], it will print all receiving data to 16 hexadecimal data for all receiving data. This would be useful when developing an application because this notifies the transmission status.

- Prints when 12 digits are received.
- Data under 12 digits will print when you press the feed button.
- Control Code (Below 1F16) prints as “.”
- Prints as “^” when 8016 or above.

16 hexadecimal indicator	ASCII indicator
[HEX DUMP MODE]	
41 42 43 44 45 46 47 47 49	A B C D E F G H I
30 31 32 33 34 35 36 37 38	0 1 2 3 4 5 6 7 8
FF 1B 69	^ . i





5 INSTALLATION

This is an example of how to mount the printer on the product.

5.1 Method by making hook shapes on the Top side and mounting the printer

Hang the two fronts of the printer on the hook and screw it to two holes on the rear.

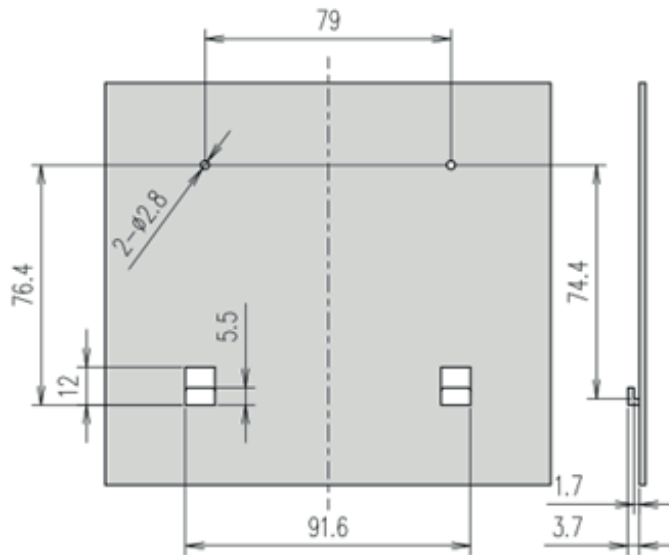
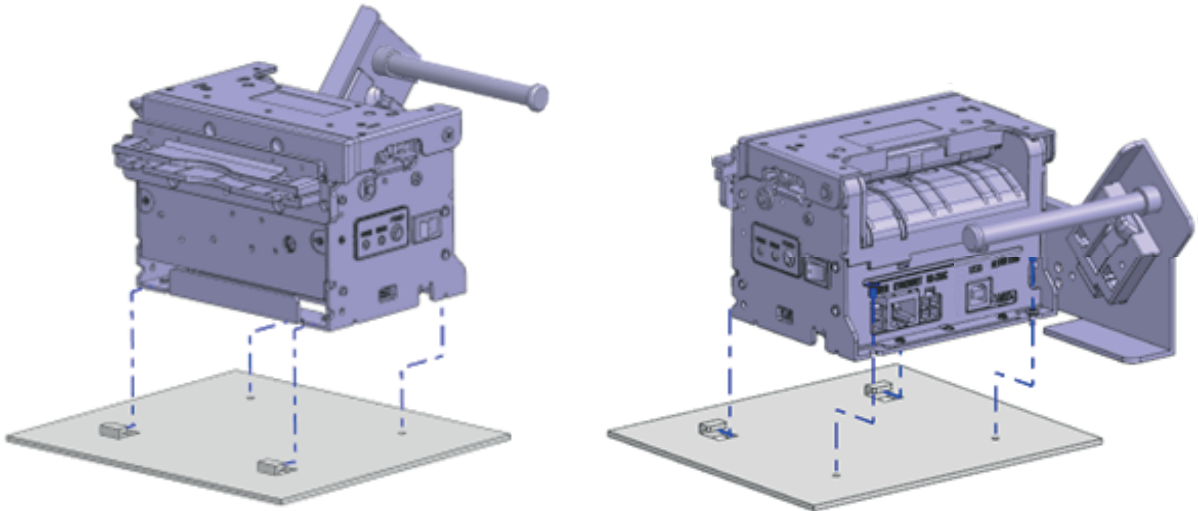

Please refer to the drawing below to design the fixture.

* (Recommended screw: M3 x 5 B-TITE)



5.2 Method by using Mount Brackets for fixing and mounting the printer

Fit the printer into the hole and screw it into the 4 holes.

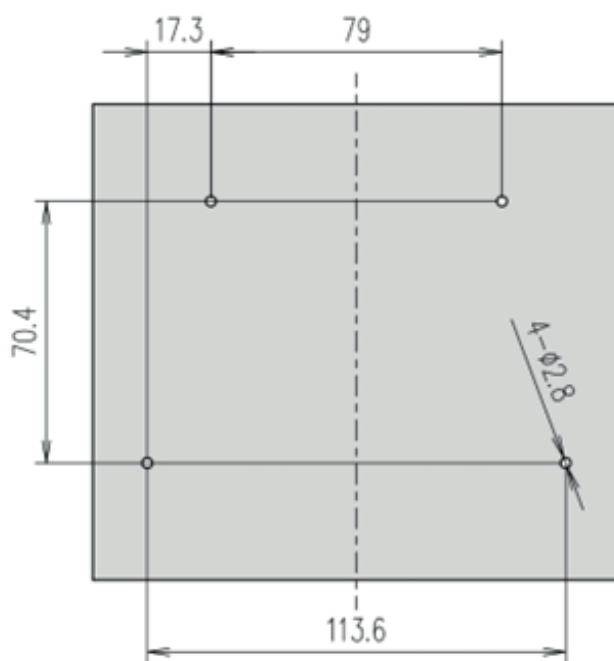
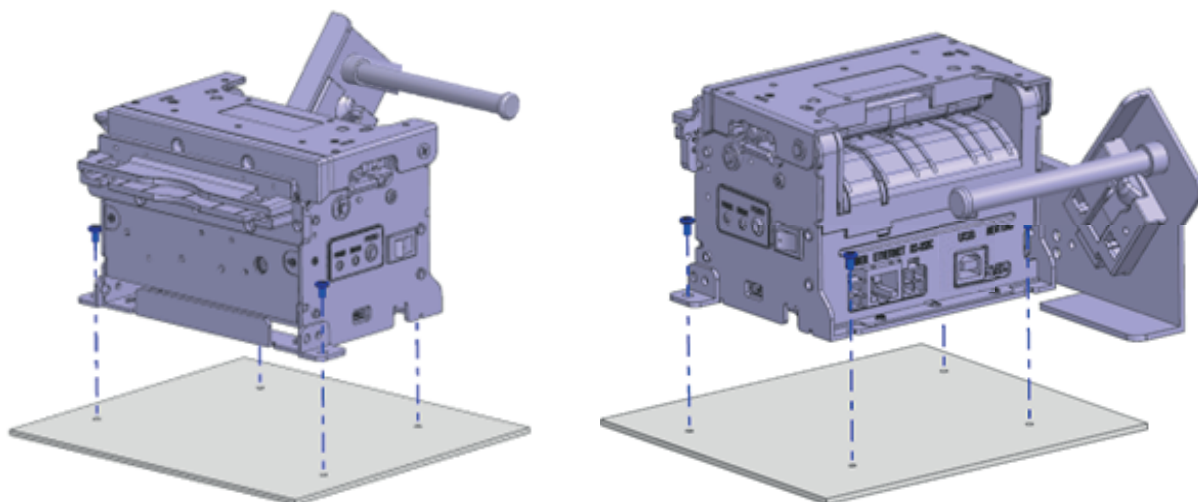

Please refer to the drawing below to design the fixture.

* (Recommended screw : M3 x 5 B-TITE)



5.3 Method by mounting in the floor (BOTTOM) side

Fit the printer into the hole and screw it into the 4 holes

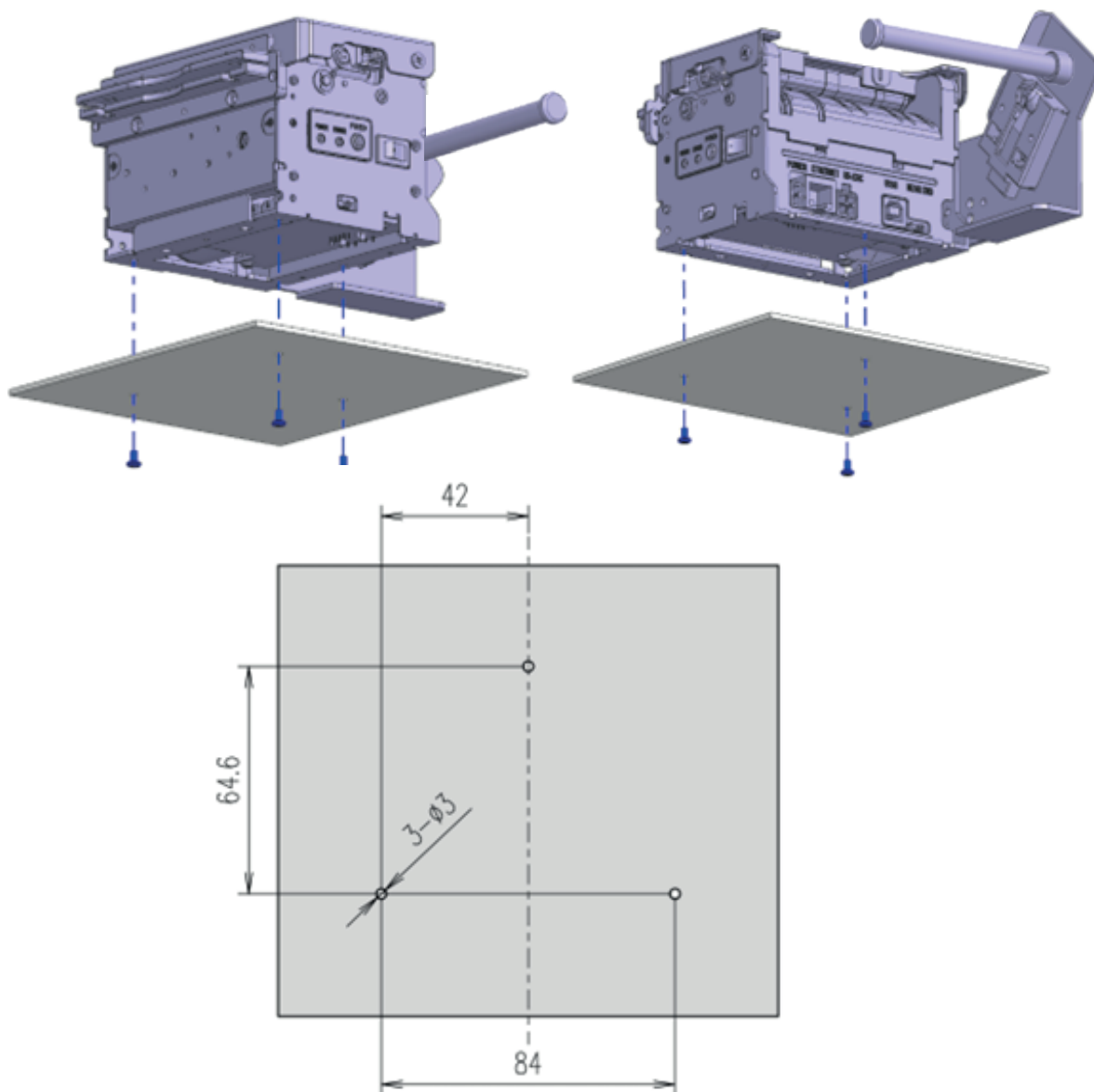

Please refer to the drawing below to design the fixture.

* (Recommended screw : M3 x 5 B-TITE)





6 PRINTER FUNCTION SETTINGS

There are two ways to set the printer's functions such as serial communication conditions, Ethernet, black mark, etc., which are: a manual setting method in which the printer itself is changed, and a method using tools such as a memory switch program that connects to a PC. For the direct communication method through the Window Driver, refer to the separate manual attached with the setting program on our website.

6.1 Setting manually

1. If the power is turned on while holding the FEED button for more than 2 seconds, the ERROR light turns off and then on and off repeatedly, and the items for which settings can be adjusted are printed as follows.

```
[MENU]
  1. Baud Rate
  2. Parity
  3. Flow control
  4. HEX Dump Mode
  5. Print density
  6. Auto Melody
  7. Cut Mode
  8. Auto buzzer
  9. Print speed

Select and then Enter...

Enter: Press the feed button once
       for more than 1second.
Select: Press the feed button many
       times less than 1second as
       menu number.
Exit:   Turn power off then on.
```

2. Item change and specification are determined by the length of time that the FEED button is pressed. Pressing the FEED button for less than 1 second will change to the next item. For example, if you want to adjust the print density, press the FEED button for the less than 1 second 5 times to change the item to "5. Print Density".
3. After that, if you press and hold the FEED button for more than 1 second, the item is specified and the current setting value is output.

```
[PRINT DENSITY]
-> 1. Normal
   2. Medium
   3. Dark
   4. Most dark

-> :Indicate current set status
Select and the Enter...
```

"->" indicates the currently set value.



4. In the same way, press for less than 1 second to toggle to the item you want to change and then set the item.

For example, if you want to change the current setting value from “1. Normal” to “4. Most Dark”, simply press the FEED button 4 times and then press and hold 1 time.

It was changed successfully!

This indicates that the change was successful.

The value is invalid, try again!

This is displayed when the selected item is invalid or when you move to another menu without changing the item.

If the change is made successfully, the changeable items printed first are displayed.

If you need to make further adjustments, you can proceed in the same way.

Turn the power off and on after making all the changes.

6.2 Set using memory switch program

Using the utility program, memory switch settings such as printer functions as well as conditions of communication the host can be set. The memory switch utility program is provided on our website.

When setting, all the contents of the memory switch are deleted, so please set again items such as code page and print options.

- Turn on the power after connecting the printer and the interface cable.
- Open the utility program and select the current communication conditions. For communication conditions, refer to the self-test parameters.

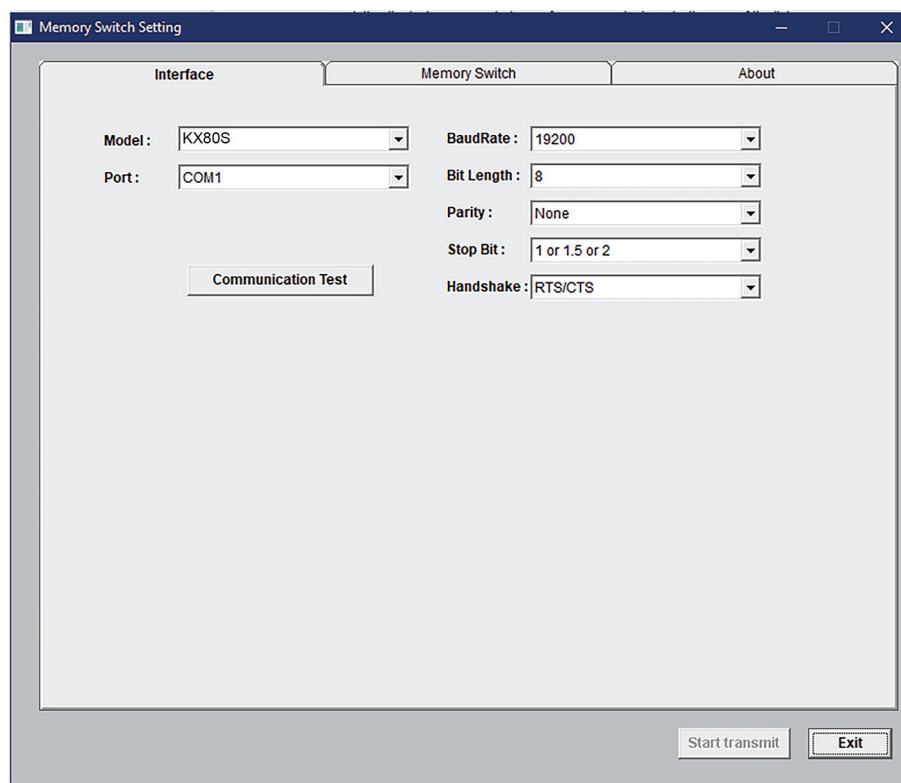

If communication is successful, the Start transmit button is activated.



- After pressing the Memory Switch tab, click KX80S in Special Model Option.

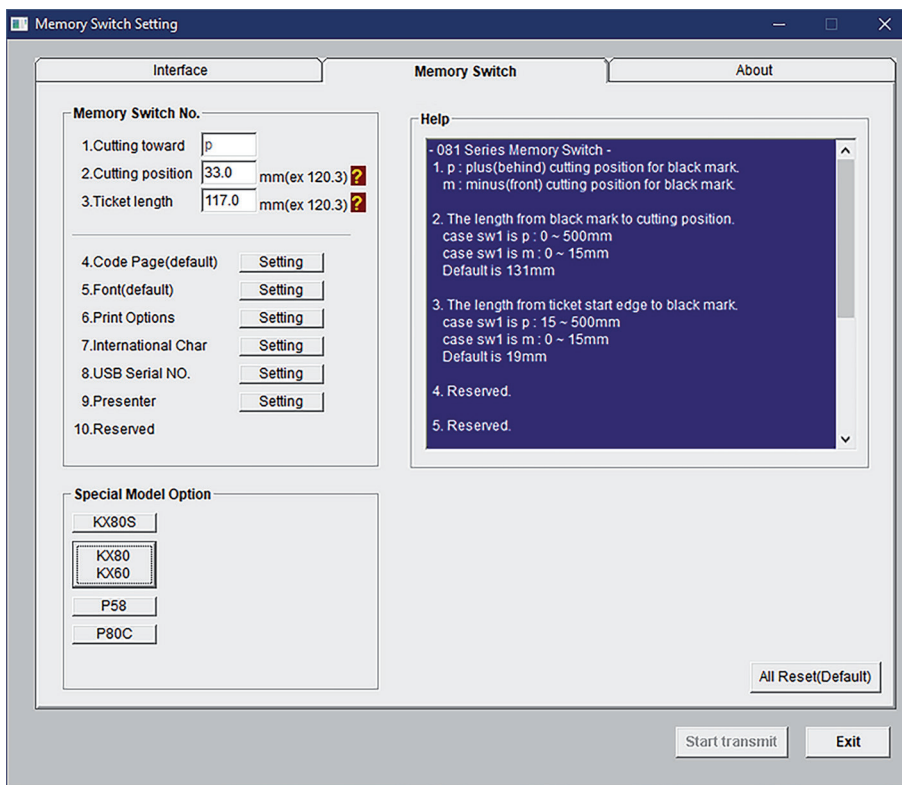

- You can set the required value when the following window appears. Note that after completing selection, you must press the 'Start transmit' button with the window open.

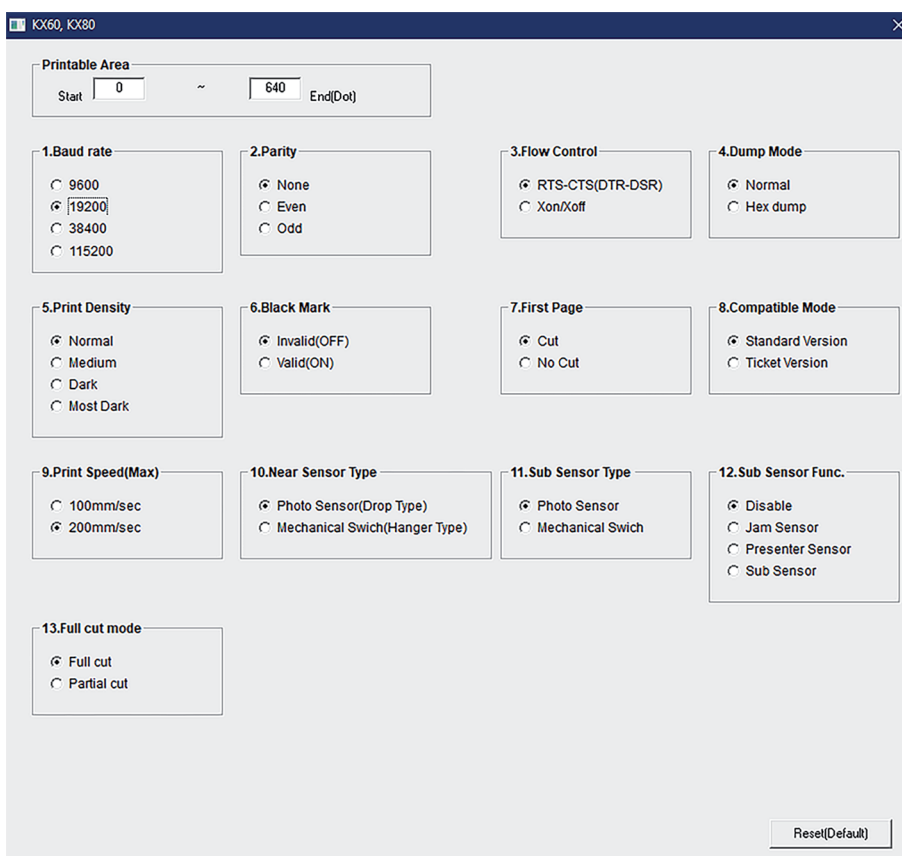

After setting, turn the power off and on to apply the set values.



6.3 Firmware update

With the adoption of flash memory, you can easily update the printer program from a PC. When updating, be sure to read the steps below.

1. Turn the power off and then back on.
2. Make sure that the communication cable is connected with the printer. (You can shorten the update time by using a USB cable.)
3. Run the provided update program, set the model name and communication port, and perform the update. The ERROR LIGHT turns off, and after a few seconds, it flashes rapidly and the update starts. Never turn off the printer power before the update is completed.
4. When the update complete mark appears, the update is completed. If there is an update error during update, the ERROR LIGHT blinks slowly. After closing the update program, check the model and communication cable for abnormalities. After checking that the values are correct, run the update program again and repeat step 1).
5. After the update is completed, it is automatically reset and becomes available to use.

For more information on updating firmware, please check our website or contact the person in charge.

6.4 Ethernet interface settings

When Using in Static IP Mode

- Connect the network cable and USB cable to the printer.
- In the printer settings, set Ethernet to ON and IP Mode to Static IP, and then turn on the power.
- Run the IP Configuration setting utility program.
- Select KX80S for the printer model and USB for the port.

The screenshot shows the 'Ethernet & WiFi Configuration Program v1.01' window. It has two tabs: 'Ethernet' (selected) and 'WiFi'. The 'Interface' section shows 'Ethernet' selected. The 'Model' dropdown is set to 'KX80S' and the 'Port' dropdown is set to 'USB'. The 'Target Parameter' section contains input fields for IP Address (253.253.253.253), Subnet Mask (255.255.255.0), Gateway (255.255.255.255), and Port Number (9100). The 'Current Parameter' section shows IP Address (192.168.1.250) and Port Number (9100). There are buttons for 'Ping', 'Connect', 'Start Write', and 'Clear Messages'. The 'WiFi Parameter' section includes fields for SSID (1~32 Characters), BSSID (Router MAC xx:xx:xx:xx:xx:xx, Leave blank if SSID is not duplicate), Security Type (Auto), and Security Key (WEP: 5 or 13 Characters, WPA: 8 ~ 32 Characters). At the bottom, there are two scrollable text areas labeled 'Send Data and General Messages' and 'Received Printer Status(Hex)'.

- Enter the IP address and gateway you want to use in the Target Parameter column and click Start Write.
- The message “End Transmit” is displayed and the setting is completed.

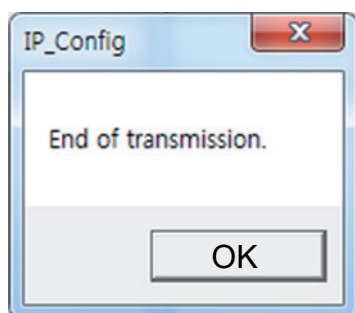



- Turn off the printer and remove the USB cable.
- Turn on the printer while pressing the FEED button.
- Self-test printing is performed and the set IP address, etc. is printed.
- After ensuring that the set values are correct, turn the power off and on, and the printer will boot with these user values, and the application can use these user values for communication.

After booting to the factory default values (Boot into Default Value), the set values cannot be changed if the IP address conflicts with the network IP address. In this case, do not use a router, and connect directly to the PC to avoid IP address conflict, or use it in Dynamic IP DHCP Mode. Refer to (Next 2) when using in Dynamic IP DHCP Mode

6.5 When using in dynamic IP DHCP mode

- Connect the network cable to the printer.
- Turn on the power by setting Ethernet ON, and setting the IP Mode to Dynamic IP DHCP. The printer starts protocol exchange communication with the host as the Error light blinks every 1 second. If connection is successful, the Error light stops blinking.

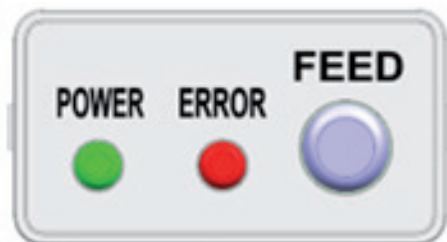

Connection attempt: Blinks at 1 second intervals.

Connection successful: Flashing stops and returns to print standby.

- Turn off the printer.
- Turn on the printer while pressing the FEED button.

Self-test printing is performed, and the IP address automatically acquired in DHCP Mode is printed.

- After checking the automatically acquired IP address, turn the power off and on, and the printer will boot up with this automatically acquired value, and applications can communicate with this value.

When booting in Dynamic IP DHCP Mode, the automatically acquired communication parameter values may change every time, so special attention is required.

If network IP address conflict occurs while booting in Static IP Mode and changing communication parameter settings, use this mode to set. However, it is recommended to use Static IP Mode for communication with the application.



6.6 Ticket paper settings

It is possible to use the memory switch utility to save the ticket paper settings to the printer.
For detailed ticket setting instructions, please refer to the manual attached to the memory switch utility on the website.



7 INTERFACE SPECIFICATION

7.1 RS-232C

Data Transfer Method	Serial
Handshake	Hardware (RTS/CTS or DTR/DSR)
Baud Rate	9600, 19200, 38400, 57600, 115200 BPS
Data bits	8 bits
Parity	None, odd, even
Stop bits	1,2 bits
Connector	HANLIM CHD1140-4
Cable	DSUB9 (Female) – 4 pin customized cable

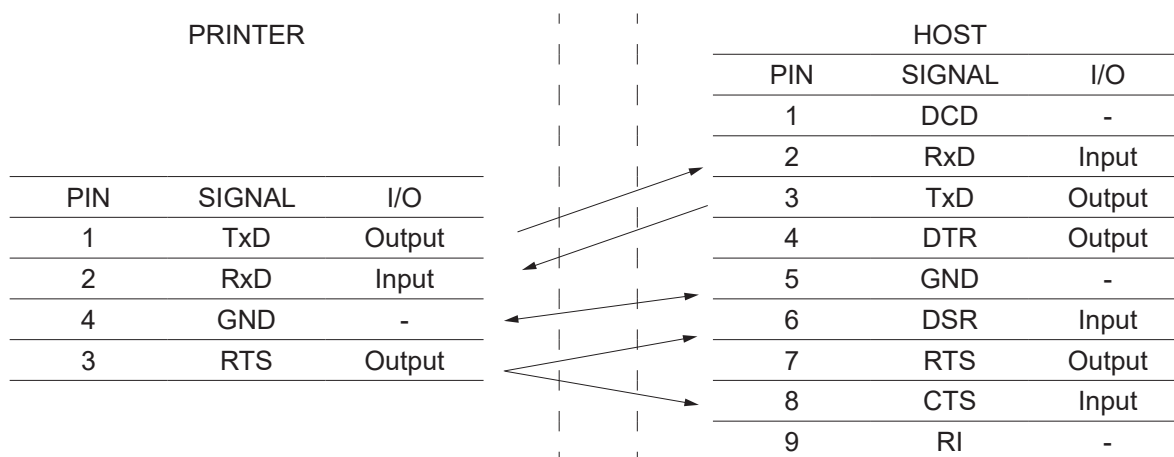



7.2 USB

Standard	USB 2.0 compatible, full speed (12 Mb) response
Connector	Type B
Cable	USB 2.0 standard cable
Data Methods	Bulk IN, Bulk OUT
Bulk OUT	End point 6
Bulk OUT	End point 2
Full Speed	Max packet size 64 byte (Bulk OUT), 64 byte (Bulk IN)



7.3 ETHERNET

Communication protocol	TCP/IP
Communication specifications	IEEE 802.3 10BASE-T and IEEE 802.3u 100BASE-TX
Connector	RB1-125BAG1A (UDE)

Pin arrangement:

PIN NO.	SIGNAL NAME	INPUT/OUTPUT	DESCRIPTION
1	TD+	OUT	Transmit Data+
2	TD-	OUT	Transmit Data-
3	TCT	OUT	
4	NC	-	None Connection
5	NC	-	None Connection
6	RCT	IN	
7	RD+	IN	Receive Data+
8	RD-	IN	Receive Data-





8 SPECIFICATIONS

8.1 Hardware specifications

Printing method	Thermal dot line printing
Dot density	203 DPI (8 dots/ mm (W) x 8 dots / mm (H))
Number of dots/line	640 dots
Paper feeding width (1 step)	0.125 mm
Paper thickness	from 50 µm to 200 µm
Paper width	80 mm, 82.5 mm
Paper outer diameter size	Φ100
Printing width	80 mm, 77 mm
Printing speed	Receipt mode: max 300 mm/s Ticket mode: max 250 mm/s
Numbers of characters per line (Default value)	Font A (12x24): 53, 51 characters Font B (9x16): 71, 68 characters Korean A (24x24): 26 characters Korean B (16x16): 40 characters
Font size	Font A (12x24): 1.50 x 3.00 mm Font B (9x16): 1.13 x 2.00 mm Korean A (24x24): 3.00 x 3.00 mm Korean B (16x16): 2.00 x 2.00 mm
Numbers of characters	English 95 Extended character (Code page): 128 x 10
Barcode	1 D: UPC-E, EAN8, EAN13, ITF,CODABAR, CODE39, CODE93, CODE128 2 D: PDF417, QR CODE
Cutter	Guillotine method (complete cutting, partial cutting possible)
Interface	RS232C USB 2.0 Full Speed Ethernet IEEE 802.3i 10Base-T (10 Mbps)
Receiving buffer size	4 Kbyte



SRAM 256 Kbyte (optional SDRAM 6 4MB expandable)

Flash ROM 2Mbyte (optional 128 MB expandable)

SMPS specifications Input voltage: from 100 V to 240 V (AC)
Output voltage: 24 V (DC)
Output current: 2.5 A, 60 W

Life Span (25 °C, average humidity) Head 150 Km
Cutter: 1000000 times
(for print duty 12%, it may vary slightly depending on the paper used)

Environment condition

Temperature Operating: from -20 °C to 60 °C (#1) (from -4 °F to 140 °F)
Storage: from -25 °C to 60 °C (from -13 °F to 140 °F)

Humidity Operating: from 40% to 85% RH (Noncon densing only)
Storage: from 40% to 95% RH

* Guaranteed operating temperature range of the product is only from 0°C to 45°C, the guaranteed life time of product may be reduced if used outside the guaranteed temperature range.



8.2 External dimensions

KX80S is the Paper holder attached Model. The Image below is based on the use of 100 mm out diameter paper

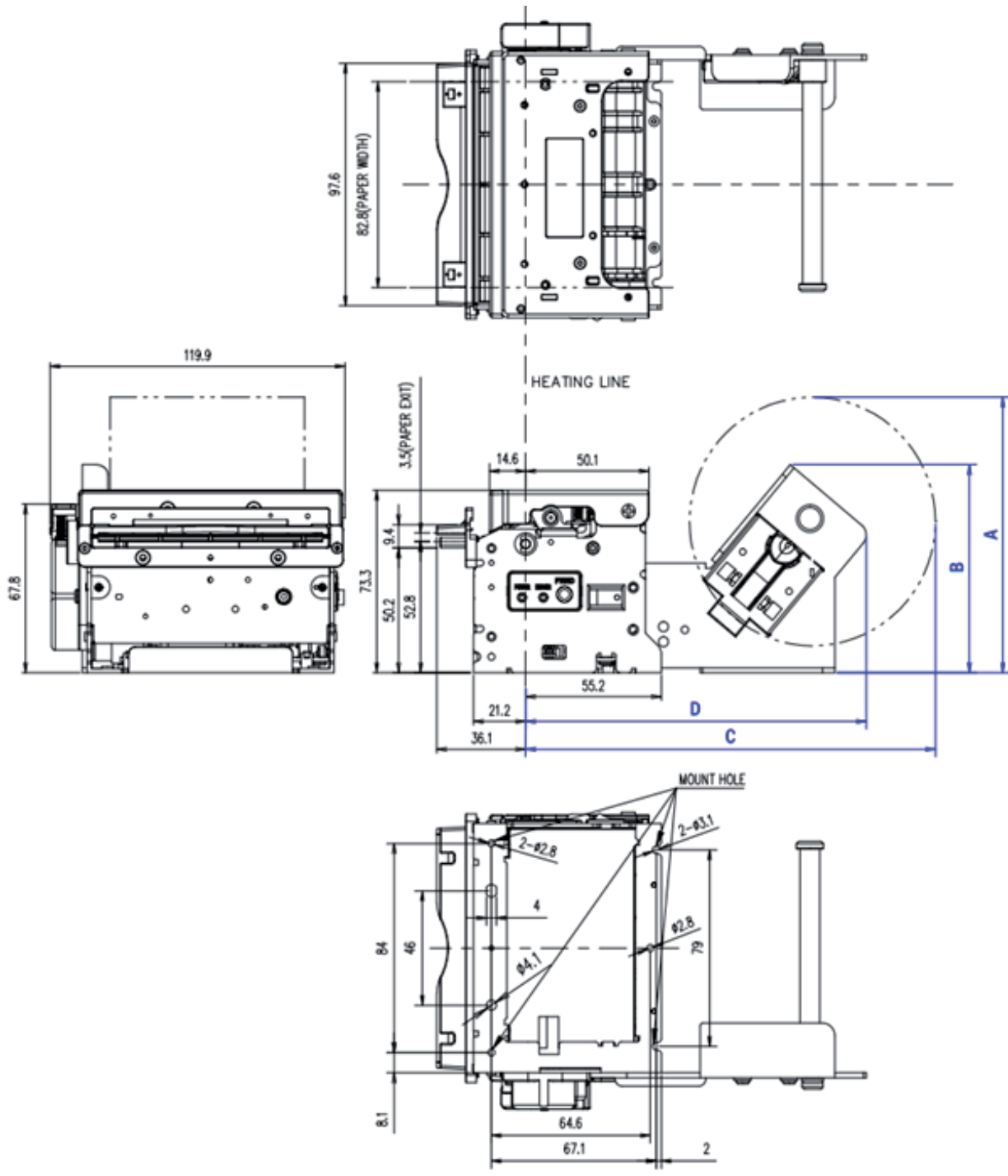

A	B	C	D
110.8	83.7	166.6	138.5



9 ACCESSORIES

The following table shows the list of available accessories for device:

963GE020000071

POWER SUPPLY

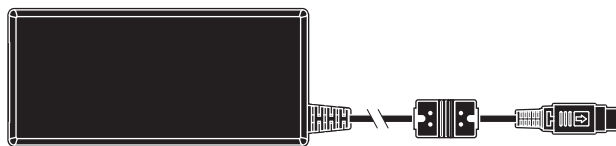

26100000000311

POWER CORD SCHUKO PLUG
length = 2 m



26900000000005

ADAPTER CABLE FOR POWER SUPPLY
length = 200 mm



26500000000356

USB CABLE TYPE A-B
length = 1.8 m



976PF010000001

RS232 CABLE DB9-MOLEX 4PIN
length = 1.8 m







10 TECHNICAL SERVICE

In case of failure, contact the technical service accessing the website www.custom4u it and using the support tools on the homepage. It is advisable to keep the identification data of the product at hand.

The product code, the serial number and the hardware release number can be found on the product



CUSTOM[®]

CUSTOM S.p.A.

World Headquarters

Via Berettine, 2/B - 43010 Fontevivo, Parma ITALY

Tel. +39 0521 680111 - Fax +39 0521 610701

info@custom.biz - www.custom.biz

All rights reserved