



TEST REPORT
IEC 62368-1
Audio/video, information and communication technology equipment
Part 1: Safety requirements

Report Number..... : LTR23022153S01
Tested by(+ signature) : Lebron Su
 Test Engineer
Witnessed by(+ signature)..... : Kelly Zhang
 Project Engineer
Approved by (+ signature) : Maarten Hou
 Designated Reviewer
Date of issue : Feb. 27, 2023
Total number of pages : 80 pages



Name of Testing Laboratory preparing the Report : **Guangdong Lintek Certification Group Co., Ltd.**
Address : 302, Building B, Xunli Science and Technology Park, No.36
 Zhangge Road, Fucheng Street, Longhua District, Shenzhen,
 Guangdong Province, China

Applicant's name : **Shenzhen Yongjiu Precision Electronics Co.,Ltd.**
Address : 7/F, Sunjet Industrial Park, No.5-1,Dawangshan Industrial Rd 2nd,
 Shajing, Bao'an, Shenzhen, 518104, China

Test specification:
Standard : IEC 62368-1:2018
 EN IEC 62368-1:2020+A11:2020
Test procedure..... : Test report
Non-standard test method..... : N/A

Test Report Form No...... : IEC62368_1E
Test Report Form(s) Originator.... : Lintek-Lab
Master TRF : Dated 2021-03-04

Test item description : Wall Charger
Trade Mark(s) : N/A
Manufacturer : Shenzhen Yongjiu Precision Electronics Co.,Ltd.
Address : 7/F, Sunjet Industrial Park, No.5 - 1,Dawangshan Industrial Rd
 2nd, Shajing, Bao'an, Shenzhen, 518104, China
Model/Type reference..... : YJ-N33, OPP142, OPP152, OPP062



Ratings..... :	Input: 100-240Va.c. 50/60Hz 1.1A Output: USB-C: 5Vd.c.3A, 9Vd.c.3A, 12Vd.c.2.5A, 15Vd.c.2.0A, 20Vd.c.1.65A, 33W Max PPS:3.3V-11Vd.c.3A USB-A: 5Vd.c.3A, 9Vd.c.3A, 12Vd.c.2.5A, 20Vd.c.1.5A 30W Max. USB-C & USB-A: 5Vd.c. 4A, 20W Max
-----------------------	---

List of Attachments (including a total number of pages in each attachment):

Appendix 1: European group differences
 Appendix 2: EU plug portion
 Appendix 3: UK plug portion
 Appendix 4: Product photos

Summary of testing:

The product covered by this report has been tested and complies with the applicable requirements of this standard.

Tests performed (name of test and test clause):

The sample(s) tested complies with the requirements EN IEC 62368-1:2020+A11:2020

Testing location:

Guangdong Lintek Certification Group Co., Ltd.
 302, Building B, Xunli Science and Technology Park,
 No.36 Zhangge Road, Fucheng Street, Longhua
 District, Shenzhen, Guangdong Province, China

Summary of compliance with National Differences (List of countries addressed):

European Group

The product fulfils the requirements of EN IEC 62368-1:2020+A11:2020

Copy of marking plate

Wall Charger
 Model: YJ-N33
 Input: 100-240V~, 50/60Hz, 1.1A
 Output:
 USB-C: 5V \Rightarrow 3.0A 9V \Rightarrow 3.0A 12V \Rightarrow 2.5A 15V \Rightarrow 2.0A 20V \Rightarrow 1.65A
 PPS: 3.3-11V \Rightarrow 3A (33W Max)
 USB-A: 5V \Rightarrow 3.0A 9V \Rightarrow 3.0A 12V \Rightarrow 2.5A 20V \Rightarrow 1.5A (30W Max)
 USB-A & USB-C: 5V \Rightarrow 4A (20W Max)
 Shenzhen Yongjiu Precision Electronics Co.,Ltd.



Made in China

Remark: the marking plates of other models are in the same pattern.

The above marking are in the minimum requirements required by safety standard. For the final production sample, the marking which do not give rise to misunderstanding may be add.

Test item particulars:	
Classification of use by	<input checked="" type="checkbox"/> Ordinary person <input checked="" type="checkbox"/> Children likely present <input type="checkbox"/> Instructed person <input type="checkbox"/> Skilled person
Supply connection.....	<input checked="" type="checkbox"/> AC mains <input type="checkbox"/> DC mains <input type="checkbox"/> not mains connected: <input type="checkbox"/> ES1 <input type="checkbox"/> ES2 <input checked="" type="checkbox"/> ES3
Supply tolerance	<input checked="" type="checkbox"/> +10%/-10% <input type="checkbox"/> +20%/-15% <input type="checkbox"/> + %/ - % <input type="checkbox"/> None
Supply connection – type	<input checked="" type="checkbox"/> pluggable equipment type A - <input type="checkbox"/> non-detachable supply cord <input type="checkbox"/> appliance coupler <input checked="" type="checkbox"/> direct plug-in <input type="checkbox"/> pluggable equipment type B - <input type="checkbox"/> non-detachable supply cord <input type="checkbox"/> appliance coupler <input type="checkbox"/> permanent connection <input type="checkbox"/> mating connector <input type="checkbox"/> other:
Considered current rating of protective device.....	<input type="checkbox"/> 16A; Location: <input type="checkbox"/> building <input checked="" type="checkbox"/> equipment <input type="checkbox"/> N/A
Equipment mobility	<input type="checkbox"/> movable <input type="checkbox"/> hand-held <input type="checkbox"/> transportable <input checked="" type="checkbox"/> direct plug-in <input type="checkbox"/> stationary <input type="checkbox"/> for building-in <input type="checkbox"/> wall/ceiling-mounted <input type="checkbox"/> SRME/rack-mounted <input type="checkbox"/> other:
Overvoltage category (OVC)	<input type="checkbox"/> OVC I <input checked="" type="checkbox"/> OVC II <input type="checkbox"/> OVC III <input type="checkbox"/> OVC IV <input type="checkbox"/> other:
Class of equipment	<input type="checkbox"/> Class I <input checked="" type="checkbox"/> Class II <input type="checkbox"/> Class III <input type="checkbox"/> Not classified <input type="checkbox"/>
Special installation location	<input checked="" type="checkbox"/> N/A <input type="checkbox"/> restricted access area <input type="checkbox"/> outdoor location <input type="checkbox"/>
Pollution degree (PD)	<input type="checkbox"/> PD 1 <input checked="" type="checkbox"/> PD 2 <input type="checkbox"/> PD 3
Manufacturer's specified T_{ma}.....	25°C <input type="checkbox"/> Outdoor:
IP protection class	<input checked="" type="checkbox"/> IPX0 <input type="checkbox"/> IP__
Power systems	<input checked="" type="checkbox"/> TN <input type="checkbox"/> TT <input type="checkbox"/> IT - V _{L-L} <input checked="" type="checkbox"/> not AC mains
Altitude during operation (m)	<input checked="" type="checkbox"/> 2000 m or less <input type="checkbox"/> m
Altitude of test laboratory (m)	<input checked="" type="checkbox"/> 2000 m or less <input type="checkbox"/> m
Mass of equipment (kg)	0.1kg

Possible test case verdicts:	
- test case does not apply to the test object.....: N/A	
- test object does meet the requirement.....: P (Pass)	
- test object does not meet the requirement.....: F (Fail)	
Testing:	
Date of receipt of test item: 2023-02-21	
Date (s) of performance of tests: 2023-02-21 to 2023-02-27	
General remarks:	
"(See Enclosure #)" refers to additional information appended to the report. "(See appended table)" refers to a table appended to the report.	
Throughout this report a <input type="checkbox"/> comma / <input checked="" type="checkbox"/> point is used as the decimal separator.	
General disclaimer:	
<p>The test results presented in this report relate only to the object tested. This report shall not be reproduced, except in full, without the written approval of the Issuing Testing Laboratory. The authenticity of this Test Report and its contents can be verified by contacting the Lintek-Lab, responsible for this Test Report.</p> <p>The test results presented in this report relate only to the object tested. If you have any objection to the testing results, please advise us within 15 working days after publishing, otherwise your claims will not be accepted.</p> <p>The test report is valid for above tested sample only and shall not be reproduced in part without written approval of Lintek-Lab.</p> <p>This document is issued by the company under its General Conditions of Service accessible www.linteklab.com. Attention is drawn to the limitation of liability, indemnification and jurisdiction issues defined therein.</p> <p>Any unauthorized alteration, forgery or falsification of the content or appearance of this document is unlawful and offenders may be prosecuted to the fullest extent of the law.</p> <p>Unless otherwise stated: (a) the results shown in this document refer only to the sample(s) tested and (b) such sample(s) are retained for 3 months.</p>	
Manufacturer's Declaration	
The application for obtaining a Test Certificate includes more than one factory location and a declaration from the Manufacturer stating that the sample(s) submitted for evaluation is (are) representative of the products from each factory has been provided	<input type="checkbox"/> Yes <input checked="" type="checkbox"/> Not applicable
When differences exist; they shall be identified in the General product information section.	
Name and address of factory (ies) : Same as Manufacturer	
General product information and other remarks:	
<p>This Unit is a Adapter</p> <p>All models are the same except model name and color. The model YJ-N33 was selected to be tested</p>	

OVERVIEW OF ENERGY SOURCES AND SAFEGUARDS				
Clause	Possible Hazard			
5	Electrically-caused injury			
Class and Energy Source (e.g. ES3: Primary circuit)	Body Part (e.g. Ordinary)	Safeguards		
		B	S	R
ES3: Internal circuit	Ordinary	N/A	N/A	Enclosure
ES1: Output	Ordinary	N/A	N/A	N/A
6	Electrically-caused fire			
Class and Energy Source (e.g. PS2: 100 Watt circuit)	Material part (e.g. Printed board)	Safeguards		
		B	1 st S	2 nd S
PS3: Internal circuit	Enclosure, PCB	No parts exceeding 90% of its spontaneous Ignition temperature	1, Plastic enclosure V-0 used. 2, PCB V-1 or better used	N/A
7	Injury caused by hazardous substances			
Class and Energy Source (e.g. Ozone)	Body Part (e.g., Skilled)	Safeguards		
		B	S	R
N/A (No such source)	N/A	N/A	N/A	N/A
8	Mechanically-caused injury			
Class and Energy Source (e.g. MS3: Plastic fan blades)	Body Part (e.g. Ordinary)	Safeguards		
		B	S	R
MS1: Edges and corners	Ordinary	N/A	N/A	N/A
MS1: Equipment mass	Ordinary	N/A	N/A	N/A
9	Thermal burn			
Class and Energy Source (e.g. TS1: Keyboard caps)	Body Part (e.g., Ordinary)	Safeguards		
		B	S	R
TS1: Accessible parts	Ordinary	N/A	N/A	N/A
10	Radiation			
Class and Energy Source (e.g. RS1: PMP sound output)	Body Part (e.g., Ordinary)	Safeguards		
		B	S	R
N/A (No such source)	N/A	N/A	N/A	N/A
Supplementary Information: “B” – Basic Safeguard; “S” – Supplementary Safeguard; “R” – Reinforced Safeguard				

ENERGY SOURCE DIAGRAM

Optional. Manufacturers are to provide the energy sources diagram identify declared energy sources and identifying the demarcations are between power sources. Recommend diagram be provided included in power supply and multipart systems.

Insert diagram below. Example diagram designs are; Block diagrams; image(s) with layered data; mechanical drawings

ES PS MS TS RS

IEC 62368-1			
Clause	Requirement + Test	Result - Remark	Verdict
4	GENERAL REQUIREMENTS		P
4.1.1	Acceptance of materials, components and subassemblies	See appended table 4.1.2	P
4.1.2	Use of components	Components which are certified to IEC and/or national standards are used correctly within their ratings. Components not covered by IEC standards are tested under the conditions present in the equipment. See also Annex G	P
4.1.3	Equipment design and construction		P
4.1.4	Specified ambient temperature for outdoor use (°C) :	Not outdoor equipment	N/A
4.1.5	Constructions and components not specifically covered	No this constructions and components.	N/A
4.1.8	Liquids and liquid filled components (LFC)	No such component used.	N/A
4.1.15	Markings and instructions	(See Annex F)	P
4.4.3	Safeguard robustness		P
4.4.3.1	General		P
4.4.3.2	Steady force tests	(See annex T.5)	P
4.4.3.3	Drop tests	(See annex T.7)	P
4.4.3.4	Impact tests	(See annex T.6)	P
4.4.3.5	Internal accessible safeguard tests	The external enclosure cannot be opened without tool.	N/A
4.4.3.6	Glass impact tests		N/A
4.4.3.7	Glass fixation tests		N/A
	Glass impact test (1J)		N/A
	Push/pull test (10 N)		N/A
4.4.3.8	Thermoplastic material tests	(See annex T.8)	P
4.4.3.9	Air comprising a safeguard	No such safeguard used	P
4.4.3.10	Accessibility, glass, safeguard effectiveness		P
4.4.4	Displacement of a safeguard by an insulating liquid		N/A
4.4.5	Safety interlocks		N/A
4.5	Explosion		P
4.5.1	General	No explosion occurs during normal/abnormal operation and single fault conditions	P
4.5.2	No explosion during normal/abnormal operating condition	(See Clause B.2, B.3)	P
	No harm by explosion during single fault conditions	(See Clause B.4)	P

IEC 62368-1			
Clause	Requirement + Test	Result - Remark	Verdict
4.6	Fixing of conductors		P
	Fix conductors not to defeat a safeguard		P
	Compliance is checked by test :	See appended table 5.4.2.2, 5.4.2.4 and 5.4.3	P
4.7	Equipment for direct insertion into mains socket-outlets		P
4.7.2	Mains plug part complies with relevant standard .. :		P
4.7.3	Torque (Nm) :	Max 0.01Nm	P
4.8	Equipment containing coin/button cell batteries		N/A
4.8.1	General	No such battery used.	N/A
4.8.2	Instructional safeguard :		N/A
4.8.3	Battery compartment door/cover construction		N/A
	Open torque test		N/A
4.8.4.2	Stress relief test		N/A
4.8.4.3	Battery replacement test		N/A
4.8.4.4	Drop test		N/A
4.8.4.5	Impact test		N/A
4.8.4.6	Crush test		N/A
4.8.5	Compliance		N/A
	30N force test with test probe		N/A
	20N force test with test hook		N/A
4.9	Likelihood of fire or shock due to entry of conductive object		P
4.10	Component requirements		N/A
4.10.1	Disconnect Device		N/A
4.10.2	Switches and relays		N/A

5	ELECTRICALLY-CAUSED INJURY		P
5.2	Classification and limits of electrical energy sources		P
5.2.2	ES1, ES2 and ES3 limits		P
5.2.2.2	Steady-state voltage and current limits :	(See appended table 5.2)	P
5.2.2.3	Capacitance limits :		N/A
5.2.2.4	Single pulse limits :		N/A
5.2.2.5	Limits for repetitive pulses :		N/A
5.2.2.6	Ringling signals		N/A
5.2.2.7	Audio signals		N/A
5.3	Protection against electrical energy sources		P
5.3.1	General Requirements for accessible parts to ordinary, instructed and skilled persons		P

IEC 62368-1			
Clause	Requirement + Test	Result - Remark	Verdict
5.3.1 a)	Accessible ES1/ES2 derived from ES2/ES3 circuits		P
5.3.1 b)	Skilled persons not unintentional contact ES3 bare conductors		P
5.3.2.1	Accessibility to electrical energy sources and safeguards	Only ES1 circuit can be accessed for this product.	P
	Accessibility to outdoor equipment bare parts		P
5.3.2.2	Contact requirements	No openings allowing entry of a probe. No access with test probe to any ES3 circuit or parts.	P
	Test with test probe from Annex V		-
5.3.2.2 a)	Air gap – electric strength test potential (V)		N/A
5.3.2.2 b)	Air gap – distance (mm)		N/A
5.3.2.3	Compliance		N/A
5.3.2.4	Terminals for connecting stripped wire		N/A
5.4	Insulation materials and requirements		P
5.4.1.2	Properties of insulating material		P
5.4.1.3	Material is non-hygroscopic	(See sub-clause 5.4.8)	P
5.4.1.4	Maximum operating temperature for insulating materials	(See appended table 5.4.1.4)	P
5.4.1.5	Pollution degrees	2	--
5.4.1.5.2	Test for pollution degree 1 environment and for an insulating compound		N/A
5.4.1.5.3	Thermal cycling test		N/A
5.4.1.6	Insulation in transformers with varying dimensions		N/A
5.4.1.7	Insulation in circuits generating starting pulses		N/A
5.4.1.8	Determination of working voltage		P
5.4.1.9	Insulating surfaces		P
5.4.1.10	Thermoplastic parts on which conductive metallic parts are directly mounted		P
5.4.1.10.2	Vicat test.....	(See appended table 5.4.1.10.2)	N/A
5.4.1.10.3	Ball pressure test	(See appended table 5.4.1.10.3)	P
5.4.2	Clearances		P
5.4.2.1	General requirements		P
	Clearances in circuits connected to AC Mains, Alternative method		P
5.4.2.2	Procedure 1 for determining clearance		N/A
	Temporary overvoltage		—
5.4.2.3	Procedure 2 for determining clearance	(See appended table 5.4.2.3)	P

IEC 62368-1			
Clause	Requirement + Test	Result - Remark	Verdict
5.4.2.3.2.2	a.c. mains transient voltage	2500Vpk	—
5.4.2.3.2.3	d.c. mains transient voltage	No d.c. mains.	—
5.4.2.3.2.4	External circuit transient voltage.....		—
5.4.2.3.2.5	Transient voltage determined by measurement		—
5.4.2.4	Determining the adequacy of a clearance using an electric strength test		N/A
5.4.2.5	Multiplication factors for clearances and test voltages		P
5.4.2.6	Clearance measurement		N/A
5.4.3	Creepage distances	(See appended table 5.4.3)	P
5.4.3.1	General		P
5.4.3.3	Material group	IIIb	—
5.4.3.4	Creepage distances measurement		P
5.4.4	Solid insulation		P
5.4.4.1	General requirements		P
5.4.4.2	Minimum distance through insulation	(See appended table 5.4.4.2)	P
5.4.4.3	Insulating compound forming solid insulation		N/A
5.4.4.4	Solid insulation in semiconductor devices		P
5.4.4.5	Insulating compound forming cemented joints		N/A
5.4.4.6	Thin sheet material		P
5.4.4.6.1	General requirements		P
5.4.4.6.2	Separable thin sheet material		N/A
	Number of layers (pcs)		N/A
5.4.4.6.3	Non-separable thin sheet material		N/A
	Number of layers (pcs)		N/A
5.4.4.6.4	Standard test procedure for non-separable thin sheet material		N/A
5.4.4.6.5	Mandrel test		N/A
5.4.4.7	Solid insulation in wound components		P
5.4.4.9	Solid insulation at frequencies >30 kHz, E_P , K_R , d , V_{PW} (V)	(See appended Table 5.4.4.9)	P
	Alternative by electric strength test, tested voltage (V), K_R		P
5.4.5	Antenna terminal insulation		P
5.4.5.1	General		P
5.4.5.2	Voltage surge test	10KV, 50 times	P
5.4.5.3	Insulation resistance (M Ω).....	>500	P
	Electric strength test		P

IEC 62368-1			
Clause	Requirement + Test	Result - Remark	Verdict
5.4.6	Insulation of internal wire as part of supplementary safeguard		N/A
5.4.7	Tests for semiconductor components and for cemented joints		N/A
5.4.8	Humidity conditioning		P
	Relative humidity (%), temperature (°C), duration (h)	93%, 40°C, 120h	—
5.4.9	Electric strength test		P
5.4.9.1	Test procedure for type test of solid insulation..... :	(See appended table 5.4.9)	P
5.4.9.2	Test procedure for routine test		N/A
5.4.10	Safeguards against transient voltages from external circuits		N/A
5.4.10.1	Parts and circuits separated from external circuits		N/A
5.4.10.2	Test methods		N/A
5.4.10.2.1	General		N/A
5.4.10.2.2	Impulse test		N/A
5.4.10.2.3	Steady-state test..... :		N/A
5.4.10.3	Verification for insulation breakdown for impulse test		N/A
5.4.11	Separation between external circuits and earth	No such circuit	N/A
5.4.11.1	Exceptions to separation between external circuits and earth		N/A
5.4.11.2	Requirements		N/A
	SPDs bridge separation between external circuit and earth		N/A
	Rated operating voltage U_{op} (V)..... :		—
	Nominal voltage U_{peak} (V)..... :		—
	Max increase due to variation ΔU_{sp}		—
	Max increase due to ageing ΔU_{sa}		—
5.4.11.3	Test method and compliance		N/A
5.4.12	Insulating liquid		N/A
5.4.12.1	General requirements		N/A
5.4.12.2	Electric strength of an insulating liquid		N/A
5.4.12.3	Compatibility of an insulating liquid		N/A
5.4.12.4	Container for insulating liquid		N/A
5.5	Components as safeguards		P
5.5.1	General		P
5.5.2	Capacitors and RC units	(See appended table 4.1.2)	P
5.5.2.1	General requirement		P

IEC 62368-1			
Clause	Requirement + Test	Result - Remark	Verdict
5.5.2.2	Safeguards against capacitor discharge after disconnection of a connector		P
5.5.3	Transformers	(See Annex G.5.3)	P
5.5.4	Optocouplers	(See sub-clause 5.4 or Annex G.12)	P
5.5.5	Relays		N/A
5.5.6	Resistors		N/A
5.5.7	SPDs		N/A
5.5.8	Insulation between the mains and an external circuit consisting of a coaxial cable		N/A
5.5.9	Safeguards for socket-outlets in outdoor equipment		N/A
	RCD rated residual operating current (mA)		—
5.6	Protective conductor	Class II	N/A
5.6.2	Requirement for protective conductors		N/A
5.6.2.1	General requirements		N/A
5.6.2.2	Colour of insulation		N/A
5.6.3	Requirement for protective earthing conductors		N/A
	Protective earthing conductor size (mm ²)		—
	Protective earthing conductor serving as a reinforced safeguard		N/A
	Protective earthing conductor serving as a double safeguard		N/A
5.6.4	Requirements for protective bonding conductors		N/A
5.6.4.1	Protective bonding conductors		N/A
	Protective bonding conductor size (mm ²)		—
5.6.4.2	Protective current rating (A)		N/A
5.6.5	Terminals for protective conductors		N/A
5.6.5.1	Terminal size for connecting protective earthing conductors (mm)		N/A
	Terminal size for connecting protective bonding conductors (mm)		N/A
5.6.5.2	Corrosion		N/A
5.6.6	Resistance of the protective bonding system		N/A
5.6.6.1	Requirements		N/A
5.6.6.2	Test Method		N/A
5.6.6.3	Resistance (Ω) or voltage drop		N/A
5.6.7	Reliable connection of a protective earthing conductor		N/A
5.6.8	Functional earthing		N/A

IEC 62368-1			
Clause	Requirement + Test	Result - Remark	Verdict
	Conductor size (mm ²)..... :		N/A
	Class II with functional earthing marking :		N/A
	Appliance inlet cl & cr (mm)..... :		N/A
5.7	Prospective touch voltage, touch current and protective conductor current		P
5.7.2	Measuring devices and networks		P
5.7.2.1	Measurement of touch current	(See appended table 5.7.4)	P
5.7.2.2	Measurement of voltage		P
5.7.3	Equipment set-up, supply connections and earth connections		P
5.7.4	Unearthed accessible parts :		P
5.7.5	Earthed accessible conductive parts :		N/A
5.7.6	Requirements when touch current exceeds ES2 limits		N/A
	Protective conductor current (mA)..... :		N/A
	Instructional Safeguard..... :		N/A
5.7.7	Prospective touch voltage and touch current associated with external circuits		N/A
5.7.7.1	Touch current from coaxial cables		N/A
5.7.7.2	Prospective touch voltage and touch current associated with paired conductor cables		N/A
5.7.8	Summation of touch currents from external circuits		N/A
	a) Equipment connected to earthed external circuits, current (mA) :		N/A
	b) Equipment connected to unearthed external circuits, current (mA) :		N/A
5.8	Backfeed safeguard in battery backed up supplies		N/A
	Mains terminal ES..... :	No such part	N/A
	Air gap (mm)..... :		N/A

6	ELECTRICALLY- CAUSED FIRE		P
6.2	Classification of PS and PIS		P
6.2.2	Power source circuit classifications..... :	All circuits are considered as PS3 except for the circuits of output terminal complied with Annex Q.	P
6.2.3	Classification of potential ignition sources		P
6.2.3.1	Arcing PIS :	All circuit inside enclosure except for output connector is claimed as Arcing PIS	P
6.2.3.2	Resistive PIS :	All circuit inside enclosure except for output connector is claimed as Resistive PIS	P

IEC 62368-1			
Clause	Requirement + Test	Result - Remark	Verdict
6.3	Safeguards against fire under normal operating and abnormal operating conditions		P
6.3.1	No ignition and attainable temperature value less than 90 % defined by ISO 871 or less than 300 °C for unknown materials	(See appended table 5.4.1.5, 6.3.2, 9.0, B.2.6)	P
	Combustible materials outside fire enclosure		N/A
6.4	Safeguards against fire under single fault conditions		P
6.4.1	Safeguard method	Method by control of fire spread applied, Fire enclosure provided.	P
6.4.2	Reduction of the likelihood of ignition under single fault conditions in PS1 circuits		N/A
6.4.3	Reduction of the likelihood of ignition under single fault conditions in PS2 and PS3 circuits		N/A
6.4.3.1	Supplementary safeguards		P
6.4.3.2	Single Fault Conditions	(See appended table 6.4.3)	P
	Special conditions for temperature limited by fuse		N/A
6.4.4	Control of fire spread in PS1 circuits		N/A
6.4.5	Control of fire spread in PS2 circuits		P
6.4.5.2	Supplementary safeguards	(See appended tables 4.1.2 and Annex G)	P
6.4.6	Control of fire spread in PS3 circuits		P
6.4.7	Separation of combustible materials from a PIS		N/A
6.4.7.2	Separation by distance		N/A
6.4.7.3	Separation by a fire barrier		N/A
6.4.8	Fire enclosures and fire barriers		P
6.4.8.2	Fire enclosure and fire barrier material properties	The V-0 material is used for the fire enclosure (overall enclosure).	P
6.4.8.2.1	Requirements for a fire barrier	No fire barrier used.	N/A
6.4.8.2.2	Requirements for a fire enclosure	The V-0 fire enclosure is used. See above.	P
6.4.8.3	Constructional requirements for a fire enclosure and a fire barrier		P
6.4.8.3.1	Fire enclosure and fire barrier openings		P
6.4.8.3.2	Fire barrier dimensions		N/A
6.4.8.3.3	Top openings and properties		N/A
	Openings dimensions (mm).....		N/A
6.4.8.3.4	Bottom openings and properties		N/A
	Openings dimensions (mm).....		N/A
	Flammability tests for the bottom of a fire enclosure		N/A

IEC 62368-1			
Clause	Requirement + Test	Result - Remark	Verdict
	Instructional Safeguard..... :		N/A
6.4.8.3.5	Side openings and properties		N/A
	Openings dimensions (mm)..... :		N/A
6.4.8.3.6	Integrity of a fire enclosure, condition met: a), b) or c)..... :		N/A
6.4.8.4	Separation of a PIS from a fire enclosure and a fire barrier distance (mm) or flammability rating..... :	Fire enclosure is made of V-0 material.	P
6.4.9	Flammability of insulating liquid..... :		N/A
6.5	Internal and external wiring		P
6.5.1	General requirements		P
6.5.2	Requirements for interconnection to building wiring..... :		N/A
6.5.3	Internal wiring size (mm ²) for socket-outlets..... :		N/A
6.6	Safeguards against fire due to the connection to additional equipment		P

7	INJURY CAUSED BY HAZARDOUS SUBSTANCES		N/A
7.2	Reduction of exposure to hazardous substances		N/A
7.3	Ozone exposure		N/A
7.4	Use of personal safeguards or personal protective equipment (PPE)		N/A
	Personal safeguards and instructions..... :		—
7.5	Use of instructional safeguards and instructions		N/A
	Instructional safeguard (ISO 7010)..... :		—
7.6	Batteries and their protection circuits		N/A

8	MECHANICALLY-CAUSED INJURY		P
8.2	Mechanical energy source classifications		P
8.3	Safeguards against mechanical energy sources		P
8.4	Safeguards against parts with sharp edges and corners		N/A
8.4.1	Safeguards		N/A
	Instructional Safeguard..... :		N/A
8.4.2	Sharp edges or corners		N/A
8.5	Safeguards against moving parts		N/A
8.5.1	Fingers, jewellery, clothing, hair, etc., contact with MS2 or MS3 parts	No moving part	N/A
	MS2 or MS3 part required to be accessible for the function of the equipment		N/A
	Moving MS3 parts only accessible to skilled person		N/A
8.5.2	Instructional safeguard..... :		N/A

IEC 62368-1			
Clause	Requirement + Test	Result - Remark	Verdict
8.5.4	Special categories of equipment containing moving parts		N/A
8.5.4.1	General		N/A
8.5.4.2	Equipment containing work cells with MS3 parts		N/A
8.5.4.2.1	Protection of persons in the work cell		N/A
8.5.4.2.2	Access protection override		N/A
8.5.4.2.2.1	Override system		N/A
8.5.4.2.2.2	Visual indicator		N/A
8.5.4.2.3	Emergency stop system		N/A
	Maximum stopping distance from the point of activation (m).....:		N/A
	Space between end point and nearest fixed mechanical part (mm)		N/A
8.5.4.2.4	Endurance requirements		N/A
	Mechanical system subjected to 100 000 cycles of operation		N/A
	- Mechanical function check and visual inspection		N/A
	- Cable assembly		N/A
8.5.4.3	Equipment having electromechanical device for destruction of media		N/A
8.5.4.3.1	Equipment safeguards		N/A
8.5.4.3.2	Instructional safeguards against moving parts		N/A
8.5.4.3.3	Disconnection from the supply		N/A
8.5.4.3.4	Cut type and test force (N).....:		N/A
8.5.4.3.5	Compliance		N/A
8.5.5	High pressure lamps		N/A
	Explosion test.....:		N/A
8.5.5.3	Glass particles dimensions (mm)		N/A
8.6	Stability of equipment		N/A
8.6.1	General		N/A
	Instructional safeguard.....:		N/A
8.6.2	Static stability		N/A
8.6.2.2	Static stability test		N/A
8.6.2.3	Downward force test		N/A
8.6.3	Relocation stability		N/A
	Wheels diameter (mm)		—
	Tilt test		N/A

IEC 62368-1			
Clause	Requirement + Test	Result - Remark	Verdict
8.6.4	Glass slide test		N/A
8.6.5	Horizontal force test		N/A
8.7	Equipment mounted to wall, ceiling or other structure		N/A
8.7.1	Mount means type	Not mounted to wall, ceiling or other structure	N/A
8.7.2	Test methods		N/A
	Test 1, additional downwards force (N).....		N/A
	Test 2, number of attachment points and test force (N).....		N/A
	Test 3 Nominal diameter (mm) and applied torque (Nm).....		N/A
8.8	Handles strength		N/A
8.8.1	General		N/A
8.8.2	Handle strength test		N/A
	Number of handles.....		—
	Force applied (N)		—
8.9	Wheels or casters attachment requirements		N/A
8.9.2	Pull test		N/A
8.10	Carts, stands and similar carriers		N/A
8.10.1	General		N/A
8.10.2	Marking and instructions		N/A
8.10.3	Cart, stand or carrier loading test		N/A
	Loading force applied (N)		N/A
8.10.4	Cart, stand or carrier impact test		N/A
8.10.5	Mechanical stability		N/A
	Force applied (N)		—
8.10.6	Thermoplastic temperature stability		N/A
8.11	Mounting means for slide-rail mounted equipment (SRME)		N/A
8.11.1	General		N/A
8.11.2	Requirements for slide rails		N/A
	Instructional Safeguard		N/A
8.11.3	Mechanical strength test		N/A
8.11.3.1	Downward force test, force (N) applied.....		N/A
8.11.3.2	Lateral push force test		N/A
8.11.3.3	Integrity of slide rail end stops		N/A
8.11.4	Compliance		N/A
8.12	Telescoping or rod antennas		N/A

IEC 62368-1			
Clause	Requirement + Test	Result - Remark	Verdict
	Button/ball diameter (mm)		—

9	THERMAL BURN INJURY		P
9.2	Thermal energy source classifications		P
9.3	Touch temperature limits		P
9.3.1	Touch temperatures of accessible parts	(See appended table)	P
9.3.2	Test method and compliance		P
9.4	Safeguards against thermal energy sources		P
9.5	Requirements for safeguards		P
9.5.1	Equipment safeguard		P
9.5.2	Instructional safeguard.....		N/A
9.6	Requirements for wireless power transmitters		N/A
9.6.1	General		N/A
9.6.2	Specification of the foreign objects		N/A
9.6.3	Test method and compliance		N/A

10	RADIATION		N/A
10.2	Radiation energy source classification		N/A
10.2.1	General classification		N/A
	Lasers		—
	Lamps and lamp systems		—
	Image projectors		—
	X-Ray		—
	Personal music player		—
10.3	Safeguards against laser radiation		N/A
	The standard(s) equipment containing laser(s) comply		N/A
10.4	Safeguards against optical radiation from lamps and lamp systems (including LED types)		N/A
10.4.1	General requirements		N/A
	Instructional safeguard provided for accessible radiation level needs to exceed		N/A
	Risk group marking and location		N/A
	Information for safe operation and installation		N/A
10.4.2	Requirements for enclosures		N/A
	UV radiation exposure		N/A
10.4.3	Instructional safeguard		N/A

IEC 62368-1			
Clause	Requirement + Test	Result - Remark	Verdict
10.5	Safeguards against X-radiation		N/A
10.5.1	Requirements		N/A
	Instructional safeguard for skilled persons		—
10.5.3	Maximum radiation (pA/kg).....		—
10.6	Safeguards against acoustic energy sources		N/A
10.6.1	General		N/A
10.6.2	Classification		N/A
	Acoustic output $L_{Aeq,T}$, dB(A).....		N/A
	Unweighted RMS output voltage (mV).....		N/A
	Digital output signal (dBFS)		N/A
10.6.3	Requirements for dose-based systems		N/A
10.6.3.1	General requirements		N/A
10.6.3.2	Dose-based warning and automatic decrease		N/A
10.6.3.3	Exposure-based warning and requirements		N/A
	30 s integrated exposure level (MEL30)		N/A
	Warning for MEL \geq 100 dB(A)		N/A
10.6.4	Measurement methods		N/A
10.6.5	Protection of persons		N/A
	Instructional safeguards		N/A
10.6.6	Requirements for listening devices (headphones, earphones, etc.)		N/A
10.6.6.1	Corded listening devices with analogue input		N/A
	Listening device input voltage (mV).....		N/A
10.6.6.2	Corded listening devices with digital input		N/A
	Max. acoustic output $L_{Aeq,T}$, dB(A)		N/A
10.6.6.3	Cordless listening devices		N/A
	Max. acoustic output $L_{Aeq,T}$, dB(A)		N/A

B	NORMAL OPERATING CONDITION TESTS, ABNORMAL OPERATING CONDITION TESTS AND SINGLE FAULT CONDITION TESTS		P
B.1	General		P
B.1.5	Temperature measurement conditions	(See appended table B.1.5)	P
B.2	Normal operating conditions		P
B.2.1	General requirements	(See Test Item Particulars and appended test tables)	P
	Audio Amplifiers and equipment with audio amplifiers		N/A
B.2.3	Supply voltage and tolerances		P

IEC 62368-1			
Clause	Requirement + Test	Result - Remark	Verdict
B.2.5	Input test	(See appended table B.2.5)	P
B.3	Simulated abnormal operating conditions		P
B.3.1	General	(See appended table B.3)	P
B.3.2	Covering of ventilation openings		N/A
	Instructional safeguard		N/A
B.3.3	DC mains polarity test		N/A
B.3.4	Setting of voltage selector	No such selector	N/A
B.3.5	Maximum load at output terminals	(See appended table B.3 & B.4)	P
B.3.6	Reverse battery polarity		N/A
B.3.7	Audio amplifier abnormal operating conditions		N/A
B.3.8	Safeguards functional during and after abnormal operating conditions	(See appended table B.3)	P
B.4	Simulated single fault conditions		P
B.4.1	General		P
B.4.2	Temperature controlling device		N/A
B.4.3	Blocked motor test	No motor used.	N/A
B.4.4	Functional insulation		P
B.4.4.1	Short circuit of clearances for functional insulation		P
B.4.4.2	Short circuit of creepage distances for functional insulation		P
B.4.4.3	Short circuit of functional insulation on coated printed boards	No coated printed board	N/A
B.4.5	Short-circuit and interruption of electrodes in tubes and semiconductors		P
B.4.6	Short circuit or disconnection of passive components		P
B.4.7	Continuous operation of components		N/A
B.4.8	Compliance during and after single fault conditions	(See appended table B.4)	P
B.4.9	Battery charging and discharging under single fault conditions		N/A
C	UV RADIATION		N/A
C.1	Protection of materials in equipment from UV radiation		N/A
C.1.2	Requirements		N/A
C.1.3	Test method		N/A
C.2	UV light conditioning test		N/A
C.2.1	Test apparatus		N/A
C.2.2	Mounting of test samples		N/A

IEC 62368-1			
Clause	Requirement + Test	Result - Remark	Verdict
C.2.3	Carbon-arc light-exposure test		N/A
C.2.4	Xenon-arc light-exposure test		N/A
D	TEST GENERATORS		N/A
D.1	Impulse test generators		N/A
D.2	Antenna interface test generator		N/A
D.3	Electronic pulse generator		N/A
E	TEST CONDITIONS FOR EQUIPMENT CONTAINING AUDIO AMPLIFIERS		N/A
E.1	Electrical energy source classification for audio signals		N/A
	Maximum non-clipped output power (W)..... :		—
	Rated load impedance (Ω) :		—
	Open-circuit output voltage (V)..... :		—
	Instructional safeguard :		—
E.2	Audio amplifier normal operating conditions		N/A
	Audio signal source type :		—
	Audio output power (W)..... :		—
	Audio output voltage (V) :		—
	Rated load impedance (Ω) :		—
	Requirements for temperature measurement		N/A
E.3	Audio amplifier abnormal operating conditions		N/A
F	EQUIPMENT MARKINGS, INSTRUCTIONS, AND INSTRUCTIONAL SAFEGUARDS		P
F.1	General		P
	Language :	English	—
F.2	Letter symbols and graphical symbols		P
F.2.1	Letter symbols according to IEC60027-1		P
F.2.2	Graphic symbols according to IEC, ISO or manufacturer specific		P
F.3	Equipment markings		P
F.3.1	Equipment marking locations		P
F.3.2	Equipment identification markings		P
F.3.2.1	Manufacturer identification :	(See copy of marking plate)	P
F.3.2.2	Model identification :	(See copy of marking plate)	P
F.3.3	Equipment rating markings	(See copy of marking plate)	P
F.3.3.1	Equipment with direct connection to mains		N/A
F.3.3.2	Equipment without direct connection to mains		P
F.3.3.3	Nature of the supply voltage :	(See copy of marking plate)	P
F.3.3.4	Rated voltage..... :	(See copy of marking plate)	P

IEC 62368-1			
Clause	Requirement + Test	Result - Remark	Verdict
F.3.3.5	Rated frequency	(See copy of marking plate)	P
F.3.3.6	Rated current or rated power.....	(See copy of marking plate)	P
F.3.3.7	Equipment with multiple supply connections		N/A
F.3.4	Voltage setting device		N/A
F.3.5	Terminals and operating devices		P
F.3.5.1	Mains appliance outlet and socket-outlet markings	No mains appliance outlets or socket-outlets	N/A
F.3.5.2	Switch position identification marking.....	No switches	N/A
F.3.5.3	Replacement fuse identification and rating markings	The current fuse is located within the equipment and not replaceable by an ordinary person or an instructed person. The current fuse is anyway marked with F1 T2A 250V.	P
	Instructional safeguards for neutral fuse		N/A
F.3.5.4	Replacement battery identification marking		N/A
F.3.5.5	Neutral conductor terminal		N/A
F.3.5.6	Terminal marking location		N/A
F.3.6	Equipment markings related to equipment classification		P
F.3.6.1	Class I equipment	Class II	N/A
F.3.6.1.1	Protective earthing conductor terminal.....		N/A
F.3.6.1.2	Protective bonding conductor terminals		N/A
F.3.6.2	Equipment class marking		P
F.3.6.3	Functional earthing terminal marking		N/A
F.3.7	Equipment IP rating marking	IPX0	—
F.3.8	External power supply output marking		P
F.3.9	Durability, legibility and permanence of marking	See below	P
F.3.10	Test for permanence of markings	The label was subjected to the permanence of marking test. The label was rubbed with cloth soaked with water for 15 sec. And then again for 15 sec. After this test there was no damage to the label. The marking on the label did not fade. There was no curling and lifting of the label edge.	P
F.4	Instructions		P
	a) Information prior to installation and initial use		N/A

IEC 62368-1			
Clause	Requirement + Test	Result - Remark	Verdict
	b) Equipment for use in locations where children not likely to be present		P
	c) Instructions for installation and interconnection		N/A
	d) Equipment intended for use only in restricted access area		N/A
	e) Equipment intended to be fastened in place		N/A
	f) Instructions for audio equipment terminals		N/A
	g) Protective earthing used as a safeguard		N/A
	h) Protective conductor current exceeding ES2 limits		N/A
	i) Graphic symbols used on equipment		P
	j) Permanently connected equipment not provided with all-pole mains switch		N/A
	k) Replaceable components or modules providing safeguard function		N/A
	l) Equipment containing insulating liquid		N/A
	m) Installation instructions for outdoor equipment		N/A
F.5	Instructional safeguards		N/A
G	COMPONENTS		P
G.1	Switches		N/A
G.1.1	General		N/A
G.1.2	Ratings, endurance, spacing, maximum load		N/A
G.1.3	Test method and compliance		N/A
G.2	Relays		N/A
G.2.1	Requirements	No such component	N/A
G.2.2	Overload test		N/A
G.2.3	Relay controlling connectors supplying power to other equipment		N/A
G.2.4	Test method and compliance		N/A
G.3	Protective devices		P
G.3.1	Thermal cut-offs	No such component	N/A
	Thermal cut-outs separately approved according to IEC 60730 with conditions indicated in a) & b)		N/A
	Thermal cut-outs tested as part of the equipment as indicated in c)		N/A
G.3.1.2	Test method and compliance		N/A
G.3.2	Thermal links		N/A
G.3.2.1	a) Thermal links tested separately according to IEC 60691 with specifics		N/A
	b) Thermal links tested as part of the equipment		N/A

IEC 62368-1			
Clause	Requirement + Test	Result - Remark	Verdict
G.3.2.2	Test method and compliance		N/A
G.3.3	PTC thermistors	No such component	N/A
G.3.4	Overcurrent protection devices		P
G.3.5	Safeguards components not mentioned in G.3.1 to G.3.4		N/A
G.3.5.1	Non-resettable devices suitably rated and marking provided		N/A
G.3.5.2	Single faults conditions..... :		N/A
G.4	Connectors		P
G.4.1	Spacings		N/A
G.4.2	Mains connector configuration..... :		N/A
G.4.3	Plug is shaped that insertion into mains socket-outlets or appliance coupler is unlikely		P
G.5	Wound components		P
G.5.1	Wire insulation in wound components		P
G.5.1.2	Protection against mechanical stress		P
G.5.2	Endurance test		N/A
G.5.2.1	General test requirements		N/A
G.5.2.2	Heat run test		N/A
	Test time (days per cycle) :		—
	Test temperature (°C)..... :		—
G.5.2.3	Wound components supplied from the mains		N/A
G.5.2.4	No insulation breakdown		N/A
G.5.3	Transformers		P
G.5.3.1	Compliance method..... :	The transformer meets the requirements given in G.5.3.2 and G.5.3.3.	P
	Position :	T1	P
	Method of protection :	See G.5.3.2.	P
G.5.3.2	Insulation	Primary windings and secondary windings are separated by Reinforced insulation.	P
	Protection from displacement of windings :	By bobbin and insulating tape	—
G.5.3.3	Transformer overload tests	(See appended table B.3)	P
G.5.3.3.1	Test conditions	Tested in the complete equipment.	P
G.5.3.3.2	Winding temperatures	(See appended table B.3)	P
G.5.3.3.3	Winding temperatures - alternative test method		N/A

IEC 62368-1			
Clause	Requirement + Test	Result - Remark	Verdict
G.5.3.4	Transformers using FIW		N/A
G.5.3.4.1	General		N/A
	FIW wire nominal diameter :		—
G.5.3.4.2	Transformers with basic insulation only		N/A
G.5.3.4.3	Transformers with double insulation or reinforced insulation :		N/A
G.5.3.4.4	Transformers with FIW wound on metal or ferrite core		N/A
G.5.3.4.5	Thermal cycling test and compliance		N/A
G.5.3.4.6	Partial discharge test		N/A
G.5.3.4.7	Routine test		N/A
G.5.4	Motors	No such component	N/A
G.5.4.1	General requirements		N/A
G.5.4.2	Motor overload test conditions		N/A
G.5.4.3	Running overload test		N/A
G.5.4.4.2	Locked-rotor overload test		N/A
	Test duration (days) :		—
G.5.4.5	Running overload test for DC motors		N/A
G.5.4.5.2	Tested in the unit		N/A
G.5.4.5.3	Alternative method		N/A
G.5.4.6	Locked-rotor overload test for DC motors		N/A
G.5.4.6.2	Tested in the unit		N/A
	Maximum Temperature :		N/A
G.5.4.6.3	Alternative method		N/A
G.5.4.7	Motors with capacitors		N/A
G.5.4.8	Three-phase motors		N/A
G.5.4.9	Series motors		N/A
	Operating voltage :		—
G.6	Wire Insulation		P
G.6.1	General	Approved wire used	P
G.6.2	Enamelled winding wire insulation		N/A
G.7	Mains supply cords		N/A
G.7.1	General requirements		N/A
	Type :	No such mains supply cords	—
G.7.2	Cross sectional area (mm ² or AWG) :		N/A
G.7.3	Cord anchorages and strain relief for non-detachable power supply cords		N/A

IEC 62368-1			
Clause	Requirement + Test	Result - Remark	Verdict
G.7.3.2	Cord strain relief		N/A
G.7.3.2.1	Requirements		N/A
	Strain relief test force (N)..... :		N/A
G.7.3.2.2	Strain relief mechanism failure		N/A
G.7.3.2.3	Cord sheath or jacket position, distance (mm) :		N/A
G.7.3.2.4	Strain relief and cord anchorage material		N/A
G.7.4	Cord Entry		N/A
G.7.5	Non-detachable cord bend protection		N/A
G.7.5.1	Requirements		N/A
G.7.5.2	Test method and compliance		N/A
	Overall diameter or minor overall dimension, D (mm) :		—
	Radius of curvature after test (mm) :		—
G.7.6	Supply wiring space		N/A
G.7.6.1	General requirements		N/A
G.7.6.2	Stranded wire		N/A
G.7.6.2.1	Requirements		N/A
G.7.6.2.2	Test with 8 mm strand		N/A
G.8	Varistors		N/A
G.8.1	General requirements	No such component	N/A
G.8.2	Safeguards against fire		N/A
G.8.2.1	General		N/A
G.8.2.2	Varistor overload test		N/A
G.8.2.3	Temporary overvoltage test		N/A
G.9	Integrated circuit (IC) current limiters		N/A
G.9.1	Requirements	No such component	N/A
	IC limiter output current (max. 5A)..... :		—
	Manufacturers' defined drift :		—
G.9.2	Test Program		N/A
G.9.3	Compliance		N/A
G.10	Resistors		N/A
G.10.1	General	No such component	N/A
G.10.2	Conditioning		N/A
G.10.3	Resistor test		N/A
G.10.4	Voltage surge test		N/A
G.10.5	Impulse test		N/A
G.10.6	Overload test		N/A

IEC 62368-1			
Clause	Requirement + Test	Result - Remark	Verdict
G.11	Capacitors and RC units		P
G.11.1	General requirements	Approved Y-cap. used (See appended table 4.1.2)	P
G.11.2	Conditioning of capacitors and RC units	(see appended table 4.1.2)	P
G.11.3	Rules for selecting capacitors	The selection followed with tables G.9, G.10, G.11 and G.12.	P
G.12	Optocouplers		P
	Optocouplers comply with IEC 60747-5-5 with specifics		P
	Type test voltage $V_{ini,a}$:		—
	Routine test voltage, $V_{ini,b}$:		—
G.13	Printed boards		P
G.13.1	General requirements		P
G.13.2	Uncoated printed boards		P
G.13.3	Coated printed boards		N/A
G.13.4	Insulation between conductors on the same inner surface		N/A
G.13.5	Insulation between conductors on different surfaces		N/A
	Distance through insulation..... :		N/A
	Number of insulation layers (pcs)..... :		—
G.13.6	Tests on coated printed boards		N/A
G.13.6.1	Sample preparation and preliminary inspection		N/A
G.13.6.2	Test method and compliance		N/A
G.14	Coating on components terminals		N/A
G.14.1	Requirements..... :		N/A
G.15	Pressurized liquid filled components		N/A
G.15.1	Requirements		N/A
G.15.2	Test methods and compliance		N/A
G.15.2.1	Hydrostatic pressure test		N/A
G.15.2.2	Creep resistance test		N/A
G.15.2.3	Tubing and fittings compatibility test		N/A
G.15.2.4	Vibration test		N/A
G.15.2.5	Thermal cycling test		N/A
G.15.2.6	Force test		N/A
G.15.3	Compliance		N/A
G.16	IC including capacitor discharge function (ICX)		N/A
G.16.1	Condition for fault tested is not required		N/A

IEC 62368-1			
Clause	Requirement + Test	Result - Remark	Verdict
	ICX with associated circuitry tested in equipment		N/A
	ICX tested separately		N/A
G.16.2	Tests		N/A
	Smallest capacitance and smallest resistance specified by ICX manufacturer for impulse test..... :		—
	Mains voltage that impulses to be superimposed on :		—
	Largest capacitance and smallest resistance for ICX tested by itself for 10000 cycles test :		—
G.16.3	Capacitor discharge test..... :		N/A
H	CRITERIA FOR TELEPHONE RINGING SIGNALS		N/A
H.1	General		N/A
H.2	Method A		N/A
H.3	Method B		N/A
H.3.1	Ringling signal		N/A
H.3.1.1	Frequency (Hz) :		—
H.3.1.2	Voltage (V) :		—
H.3.1.3	Cadence; time (s) and voltage (V) :		—
H.3.1.4	Single fault current (mA):..... :		—
H.3.2	Tripping device and monitoring voltage		N/A
H.3.2.1	Conditions for use of a tripping device or a monitoring voltage		N/A
H.3.2.2	Tripping device		N/A
H.3.2.3	Monitoring voltage (V) :		N/A
J	INSULATED WINDING WIRES FOR USE WITHOUT INTERLEAVED INSULATION		P
J.1	General		N/A
	Winding wire insulation..... :		—
	Solid round winding wire, diameter (mm) :		N/A
	Solid square and rectangular (flatwise bending) winding wire, cross-sectional area (mm ²)..... :		N/A
J.2/J.3	Tests and Manufacturing		—
K	SAFETY INTERLOCKS		N/A
K.1	General requirements		N/A
	Instructional safeguard :		N/A
K.2	Components of safety interlock safeguard mechanism		N/A
K.3	Inadvertent change of operating mode		N/A
K.4	Interlock safeguard override		N/A

IEC 62368-1			
Clause	Requirement + Test	Result - Remark	Verdict
K.5	Fail-safe		N/A
K.5.1	Under single fault condition		N/A
K.6	Mechanically operated safety interlocks		N/A
K.6.1	Endurance requirement		N/A
K.6.2	Test method and compliance		N/A
K.7	Interlock circuit isolation		N/A
K.7.1	Separation distance for contact gaps & interlock circuit elements		N/A
	In circuit connected to mains, separation distance for contact gaps (mm)..... :		N/A
	In circuit isolated from mains, separation distance for contact gaps (mm)..... :		N/A
	Electric strength test before and after the test of K.7.2		N/A
K.7.2	Overload test, Current (A)		N/A
K.7.3	Endurance test		N/A
K.7.4	Electric strength test		N/A
L	DISCONNECT DEVICES		P
L.1	General requirements		P
L.2	Permanently connected equipment		N/A
L.3	Parts that remain energized		N/A
L.4	Single-phase equipment	Disconnect device disconnects all poles simultaneously.	P
L.5	Three-phase equipment		N/A
L.6	Switches as disconnect devices		N/A
L.7	Plugs as disconnect devices		N/A
L.8	Multiple power sources		N/A
	Instructional safeguard		N/A
M	EQUIPMENT CONTAINING BATTERIES AND THEIR PROTECTION CIRCUITS		N/A
M.1	General requirements		N/A
M.2	Safety of batteries and their cells		N/A
M.2.1	Batteries and their cells comply with relevant IEC standards		N/A
M.3	Protection circuits for batteries provided within the equipment		N/A
M.3.1	Requirements		N/A
M.3.2	Test method		N/A
	Overcharging of a rechargeable battery		N/A
	Excessive discharging		N/A

IEC 62368-1			
Clause	Requirement + Test	Result - Remark	Verdict
	Unintentional charging of a non-rechargeable battery		N/A
	Reverse charging of a rechargeable battery		N/A
M.3.3	Compliance		N/A
M.4	Additional safeguards for equipment containing a portable secondary lithium battery		N/A
M.4.1	General		N/A
M.4.2	Charging safeguards		N/A
M.4.2.1	Requirements		N/A
M.4.2.2	Compliance..... :		N/A
M.4.3	Fire enclosure :		N/A
M.4.4	Drop test of equipment containing a secondary lithium battery		N/A
M.4.4.2	Preparation and procedure for the drop test		N/A
M.4.4.3	Drop, Voltage on reference and dropped batteries (V); voltage difference during 24 h period (%): :		N/A
M.4.4.4	Check of the charge/discharge function		N/A
M.4.4.5	Charge / discharge cycle test		N/A
M.4.4.6	Compliance		N/A
M.5	Risk of burn due to short-circuit during carrying		N/A
M.5.1	Requirement		N/A
M.5.2	Test method and compliance		N/A
M.6	Safeguards against short-circuits		N/A
M.6.1	External and internal faults		N/A
M.6.2	Compliance		N/A
M.7	Risk of explosion from lead acid and NiCd batteries		N/A
M.7.1	Ventilation preventing explosive gas concentration		N/A
	Calculated hydrogen generation rate :		N/A
M.7.2	Test method and compliance		N/A
	Minimum air flow rate, Q (m ³ /h)..... :		N/A
M.7.3	Ventilation tests		N/A
M.7.3.1	General		N/A
M.7.3.2	Ventilation test – alternative 1		N/A
	Hydrogen gas concentration (%)..... :		N/A
M.7.3.3	Ventilation test – alternative 2		N/A
	Obtained hydrogen generation rate..... :		N/A
M.7.3.4	Ventilation test – alternative 3		N/A
	Hydrogen gas concentration (%)..... :		N/A

IEC 62368-1			
Clause	Requirement + Test	Result - Remark	Verdict
M.7.4	Marking		N/A
M.8	Protection against internal ignition from external spark sources of batteries with aqueous electrolyte		N/A
M.8.1	General		N/A
M.8.2	Test method		N/A
M.8.2.1	General		N/A
M.8.2.2	Estimation of hypothetical volume V_z (m ³ /s)..... :		—
M.8.2.3	Correction factors		—
M.8.2.4	Calculation of distance d (mm)		—
M.9	Preventing electrolyte spillage		N/A
M.9.1	Protection from electrolyte spillage		N/A
M.9.2	Tray for preventing electrolyte spillage		N/A
M.10	Instructions to prevent reasonably foreseeable misuse		N/A
	Instructional safeguard		N/A
N	ELECTROCHEMICAL POTENTIALS		P
	Material(s) used	Pollution degree considered	—
O	MEASUREMENT OF CREEPAGE DISTANCES AND CLEARANCES		P
	Value of X (mm)..... :		—
P	SAFEGUARDS AGAINST CONDUCTIVE OBJECTS		P
P.1	General		N/A
P.2	Safeguards against entry or consequences of entry of a foreign object		N/A
P.2.1	General		N/A
P.2.2	Safeguards against entry of a foreign object		N/A
	Location and Dimensions (mm)		—
P.2.3	Safeguards against the consequences of entry of a foreign object		N/A
P.2.3.1	Safeguard requirements		N/A
	The ES3 and PS3 keep-out volume in Figure P.3 not applicable to transportable equipment		N/A
	Transportable equipment with metalized plastic parts		N/A
P.2.3.2	Consequence of entry test..... :		N/A
P.3	Safeguards against spillage of internal liquids		N/A
P.3.1	General		N/A
P.3.2	Determination of spillage consequences		N/A
P.3.3	Spillage safeguards		N/A
P.3.4	Compliance		N/A

IEC 62368-1			
Clause	Requirement + Test	Result - Remark	Verdict
P.4	Metallized coatings and adhesives securing parts		N/A
P.4.1	General		N/A
P.4.2	Tests		N/A
	Conditioning, T _c (°C)	:	—
	Duration (weeks).....	:	—
Q	CIRCUITS INTENDED FOR INTERCONNECTION WITH BUILDING WIRING		P
Q.1	Limited power sources		P
Q.1.1	Requirements		P
	a) Inherently limited output		N/A
	b) Impedance limited output		P
	c) Regulating network limited output		P
	d) Overcurrent protective device limited output		N/A
	e) IC current limiter complying with G.9		N/A
Q.1.2	Test method and compliance	:	P
	Current rating of overcurrent protective device (A)	:	P
Q.2	Test for external circuits – paired conductor cable		N/A
	Maximum output current (A)	:	N/A
	Current limiting method	:	—
R	LIMITED SHORT CIRCUIT TEST		N/A
R.1	General		N/A
R.2	Test setup		N/A
	Overcurrent protective device for test.....	:	—
R.3	Test method		N/A
	Cord/cable used for test	:	—
R.4	Compliance		N/A
S	TESTS FOR RESISTANCE TO HEAT AND FIRE		N/A
S.1	Flammability test for fire enclosures and fire barrier materials of equipment where the steady state power does not exceed 4 000 W		N/A
	Samples, material	:	—
	Wall thickness (mm)	:	—
	Conditioning (°C)	:	—
	Test flame according to IEC 60695-11-5 with conditions as set out		N/A
	- Material not consumed completely		N/A
	- Material extinguishes within 30s		N/A

IEC 62368-1			
Clause	Requirement + Test	Result - Remark	Verdict
	- No burning of layer or wrapping tissue		N/A
S.2	Flammability test for fire enclosure and fire barrier integrity		N/A
	Samples, material		—
	Wall thickness (mm)		—
	Conditioning (°C)		—
S.3	Flammability test for the bottom of a fire enclosure		N/A
S.3.1	Mounting of samples		N/A
S.3.2	Test method and compliance		N/A
	Mounting of samples		—
	Wall thickness (mm)		—
S.4	Flammability classification of materials		N/A
S.5	Flammability test for fire enclosures and fire barrier materials of equipment where the steady state power exceeding 4 000 W		N/A
	Samples, material		—
	Wall thickness (mm)		—
	Conditioning (°C)		—
T	MECHANICAL STRENGTH TESTS		P
T.1	General		P
T.2	Steady force test, 10 N	(See appended table T.2)	P
T.3	Steady force test, 30 N	(See appended table T.3)	N/A
T.4	Steady force test, 100 N	(See appended table T.4)	N/A
T.5	Steady force test, 250 N	(See appended table T.5)	P
T.6	Enclosure impact test	(See appended table T.6)	P
	Fall test		P
	Swing test		N/A
T.7	Drop test	(See appended table T.7)	P
T.8	Stress relief test.....	(See appended table T.8)	P
T.9	Glass Impact Test	No parts made of glass	N/A
T.10	Glass fragmentation test		N/A
	Number of particles counted.....		N/A
T.11	Test for telescoping or rod antennas		N/A
	Torque value (Nm)		N/A
U	MECHANICAL STRENGTH OF CATHODE RAY TUBES (CRT) AND PROTECTION AGAINST THE EFFECTS OF IMPLOSION		N/A
U.1	General		N/A
	Instructional safeguard :		N/A

IEC 62368-1			
Clause	Requirement + Test	Result - Remark	Verdict
U.2	Test method and compliance for non-intrinsically protected CRTs		N/A
U.3	Protective screen		N/A
V	DETERMINATION OF ACCESSIBLE PARTS		P
V.1	Accessible parts of equipment		P
V.1.1	General		P
V.1.2	Surfaces and openings tested with jointed test probes		P
V.1.3	Openings tested with straight unjointed test probes		P
V.1.4	Plugs, jacks, connectors tested with blunt probe		P
V.1.5	Slot openings tested with wedge probe		P
V.1.6	Terminals tested with rigid test wire		P
V.2	Accessible part criterion		P
X	ALTERNATIVE METHOD FOR DETERMINING CLEARANCES FOR INSULATION IN CIRCUITS CONNECTED TO AN AC MAINS NOT EXCEEDING 420 V PEAK (300 V RMS)		N/A
	Clearance		N/A
Y	CONSTRUCTION REQUIREMENTS FOR OUTDOOR ENCLOSURES		N/A
Y.1	General	Not such equipment	N/A
Y.2	Resistance to UV radiation		N/A
Y.3	Resistance to corrosion		N/A
Y.3	Resistance to corrosion		N/A
Y.3.1	Metallic parts of outdoor enclosures are resistant to effects of water-borne contaminants by		N/A
Y.3.2	Test apparatus		N/A
Y.3.3	Water – saturated sulphur dioxide atmosphere		N/A
Y.3.4	Test procedure		N/A
Y.3.5	Compliance		N/A
Y.4	Gaskets		N/A
Y.4.1	General		N/A
Y.4.2	Gasket tests		N/A
Y.4.3	Tensile strength and elongation tests		N/A
	Alternative test methods		N/A
Y.4.4	Compression test		N/A
Y.4.5	Oil resistance		N/A
Y.4.6	Securing means		N/A
Y.5	Protection of equipment within an outdoor enclosure		N/A
Y.5.1	General		N/A
Y.5.2	Protection from moisture		N/A

IEC 62368-1			
Clause	Requirement + Test	Result - Remark	Verdict
	Relevant tests of IEC 60529 or Y.5.3		N/A
Y.5.3	Water spray test		N/A
Y.5.4	Protection from plants and vermin		N/A
Y.5.5	Protection from excessive dust		N/A
Y.5.5.1	General		N/A
Y.5.5.2	IP5X equipment		N/A
Y.5.5.3	IP6X equipment		N/A
Y.6	Mechanical strength of enclosures		N/A
Y.6.1	General		N/A
Y.6.2	Impact test		N/A

IEC 62368-1			
Clause	Requirement + Test	Result - Remark	Verdict

5.2	TABLE: Classification of electrical energy sources						P
Supply Voltage	Location (e.g. circuit designation)	Test conditions	Parameters				ES Class
			U (V)	I (mA)	Type ¹⁾	Additional Info ²⁾	
264Vac, 60Hz	Primary	Normal	--	--	--	--	ES3
		Abnormal: Overload	--	--	--	--	
		Single fault:	--	--	--	--	
264Vac, 60Hz	USB-A Output + to -	Normal	20.06	--	--	DC	ES1
		Abnormal: Overload	20.06	--	--	DC	
		Single fault: R6 SC	0	--	--	DC	
264Vac, 60Hz	USB-A Output +/- to earth	Normal	--	0.20mApk	--	60	ES1
		Abnormal Overload	--	0.20mApk	--	60	
		Single fault: R6 SC	--	0.26mApk	--	60	
264Vac, 60Hz	USB-C Output + to -	Normal	20.18	--	--	DC	ES1
		Abnormal: Overload	20.18	--	--	DC	
		Single fault: R6 SC	0	--	--	DC	
264Vac, 60Hz	USB-C Output +/- to earth	Normal	--	0.20mApk	--	60	ES1
		Abnormal Overload	--	0.20mApk	--	60	
		Single fault: R6 SC	--	0.26mApk	--	60	

Supplementary information:
1) Type: Steady state (SS), Capacitance (CP), Single pulse (SP), Repetitive pulses (RP), etc.
2) Additional Info: Frequency, Pulse duration, Pulse off time, Capacitance value, etc.

5.4.1.10.2	TABLE: Vicat softening temperature of thermoplastics				N/A
Method.....:					—
Object/ Part No./Material	Manufacturer/trademark	Thickness (mm)	T softening (°C)		
--	--	--	--		
Supplementary information:					

IEC 62368-1				
Clause	Requirement + Test	Result - Remark	Verdict	
5.4.1.10.3	TABLE: Ball pressure test of thermoplastics			P
Allowed impression diameter (mm)		2mm	—	
Object/Part No./Material	Manufacturer/trademark	Thickness (mm)	Test temperature (°C)	Impression diameter (mm)
Plug holder	--	2.0	125	1.0
Supplementary information:				

5.4.2, 5.4.3 TABLE: Minimum Clearances/Creepage distance							P
Clearance (cl) and creepage distance (cr) at/of/between:	U_p (V)	U_{rms} (V)	Freq ¹⁾ (Hz)	Required cl (mm)	cl (mm)	Required cr (mm)	cr (mm)
Primary traces of different polarity before fuse F1	420	240	60	1.5	3.7	2.4	3.7
Primary traces under fuser F1	420	240	60	1.5	3.3	2.4	3.3
CY1 primary to secondary	420	240	60	3.0	6.5	4.8	6.5
U3 primary to secondary	420	240	60	3.0	7.6	4.8	7.6
T1 primary to secondary	450	250	45.6K	3.0	>6.0	5.0	>6.0
T1 core to secondary	450	250	45.6K	3.0	>6.0	5.0	>6.0
T1 primary trace to secondary trace	450	250	45.6K	3.0	>6.0	5.0	>6.0
Primary part to accessible enclosure	450	250	60	3.0	>6.0	5.0	>6.0
Supplementary information:							

5.4.4.2 TABLE: Minimum distance through insulation					P
Distance through insulation (DTI) at/of	Peak voltage (V)	Insulation	Required DTI (mm)	Measured DTI (mm)	
Enclosure	450	Reinforce	0.4	Min 2.0	
Supplementary information:					

5.4.4.9 TABLE: Solid insulation at frequencies >30 kHz						P
Insulation material	E_p	Frequency (kHz)	K_R	Thickness d (mm)	Insulation	V_{PW} (Vpk)
Bobbin of transformer T1	0.75	45.6K	0.71	1.0	Reinforce	450
Supplementary information:						

5.4.9 TABLE: Electric strength tests				P
Test voltage applied between:	Voltage shape (Surge, Impulse, AC, DC, etc.)	Test voltage (V)	Breakdown Yes / No	

IEC 62368-1			
Clause	Requirement + Test	Result - Remark	Verdict
L to N (primary fuse F1 disconnected)	DC	2500	No
Transformer T1: Primary winding to secondary winding	DC	4000	No
Transformer T1: Core to secondary winding	DC	4000	No
Transformer T1: One layer of insulation tape	DC	4000	No
L&N to secondary output terminal	DC	4000	No
L&N and plastic enclosure with metal foil	DC	4000	No
Supplementary information:			

5.5.2.2	TABLE: Stored discharge on capacitors					N/A
Location	Supply voltage (V)	Operating and fault condition ¹⁾	Switch position	Measured voltage (Vpk)	ES Class	
Supplementary information: X-capacitors installed for testing: <input type="checkbox"/> bleeding resistor rating: <input type="checkbox"/> ICX: 1) Normal operating condition (e.g., normal operation, or open fuse), SC= short circuit, OC= open circuit						

5.6.6	TABLE: Resistance of protective conductors and terminations				N/A
Location	Test current (A)	Duration (min)	Voltage drop (V)	Resistance (Ω)	
--	--	--	--	--	
Supplementary information:					

5.7.4	TABLE: Unearthed accessible parts					P
Location	Operating and fault conditions	Supply Voltage (V)	Parameters			ES class
			Voltage (V_{rms} or V_{pk})	Current (A_{rms} or A_{pk})	Freq. (Hz)	
L/N to plastic enclosure cover with metal foil	Normal	264	--	0.005	60	ES1
	Single fault –R6 SC	264	--	0.005	60	ES1
L/N to output	Normal	264	--	0.10	60	ES1
	Single fault –R6 SC	264	--	0.13	60	ES1
Supplementary information: Abbreviation: SC= short circuit; OC= open circuit						

IEC 62368-1			
Clause	Requirement + Test	Result - Remark	Verdict
5.7.5	TABLE: Earthed accessible conductive part		N/A
Supply voltage (V)			—
Phase(s)	<input type="checkbox"/> Single Phase; <input type="checkbox"/> Three Phase: <input type="checkbox"/> Delta <input type="checkbox"/> Wye		
Power Distribution System	<input type="checkbox"/> TN <input type="checkbox"/> TT <input type="checkbox"/> IT		
Location	Fault Condition No in IEC 60990 clause 6.2.2	Touch current (mA)	Comment
Supplementary Information:			

5.8	TABLE: Backfeed safeguard in battery backed up supplies					N/A
Location	Supply voltage (V)	Operating and fault condition	Time (s)	Open-circuit voltage (V)	Touch current (A)	ES Class
--	--	--	--	--	--	--
Supplementary information:						
Abbreviation: SC= short circuit, OC= open circuit						

IEC 62368-1						
Clause	Requirement + Test	Result - Remark				Verdict
6.2.2	TABLE: Power source circuit classifications					P
Location	Operating and fault condition	Voltage (V)	Current (A)	Max. Power ¹⁾ (W)	Time (S)	PS class
USB-A Output 5V	Normal	4.55	3.50	15.89	3s	PS2
	Single fault: R6 SC	0	0	0	3s	PS1
USB-A Output 9V	Normal	8.65	3.20	27.51	3s	PS2
	Single fault: R6SC	0	0	0	3s	PS1
USB-A Output 12V	Normal	11.71	2.80	32.77	3s	PS2
	Single fault: R6 SC	0	0	0	3s	PS1
USB-A Output 20V	Normal	19.89	1.65	32.81	3s	PS2
	Single fault: R6 SC	0	0	0	3s	PS1
USB-C Output 5V	Normal	4.65	3.50	16.23	3s	PS2
	Single fault: R6 SC	0	0	0	3s	PS1
USB-C Output 9V	Normal	8.62	3.30	28.42	3s	PS2
	Single fault: R6 SC	0	0	0	3s	PS1
USB-C Output 12V	Normal	11.70	2.80	32.74	3s	PS2
	Single fault: R6 SC	0	0	0	3s	PS1
USB-C Output 15V	Normal	14.78	2.30	33.81	3s	PS2
	Single fault: R6 SC	0	0	0	3s	PS1
USB-C Output 20V	Normal	19.99	1.75	34.98	3s	PS2
	Single fault: R6 SC	0	0	0	3s	PS1
Supplementary information:						

6.2.3.1	TABLE: Determination of Arcing PIS				P
Location	Open circuit voltage after 3 s (Vpk)	Measured r.m.s current (A)	Calculated value	Arcing PIS? Yes / No	
All circuits/components	--	--	--	Yes(Declared)	
Supplementary information:					
An Arcing PIS requires a minimum of 50 V (peak) a.c. or d.c. An Arcing PIS is established when the product of the open circuit voltage (V_p) and normal operating condition rms current (I_{rms}) is greater than 15.					

IEC 62368-1			
Clause	Requirement + Test	Result - Remark	Verdict

6.2.3.2	TABLE: Determination of resistive PIS			P
Location	Operating and fault condition	Dissipate power (W)	Arcing PIS? Yes / No	
All circuits/components	--	--	Yes(Declared)	
Supplementary information: A combination of voltmeter, VA and ammeter IA may be used instead of a wattmeter. If a separate voltmeter and ammeter are used, the product of (VA x IA) is used to determine Resistive PIS classification. A Resistive PIS: (a) dissipates more than 15 W, measured after 30 s of normal operation, <u>or</u> (b) under single fault conditions has either a power exceeding 100 W measured immediately after the introduction of the fault if electronic circuits, regulators or PTC devices are used, or has an available power exceeding 15 W measured 30 s after introduction of the fault.				

8.5.5	TABLE: High pressure lamp				N/A
Lamp manufacturer	Lamp type	Explosion method	Longest axis of glass particle (mm)	Particle found beyond 1 m Yes / No	
--	--	--	--	--	
Supplementary information:					

9.6	TABLE: Temperature measurements for wireless power transmitters								N/A
Supply voltage (V)..... :		--						—	
Max. transmit power of transmitter (W)..... :		--						—	
Foreign objects	w/o receiver and direct contact		with receiver and direct contact		with receiver and at distance of 2 mm		with receiver and at distance of 5 mm		
	Object (°C)	Ambient (°C)	Object (°C)	Ambient (°C)	Object (°C)	Ambient (°C)	Object (°C)	Ambient (°C)	
--	--	--	--	--	--	--	--	--	
--	--	--	--	--	--	--	--	--	
--	--	--	--	--	--	--	--	--	
Supplementary information:									

IEC 62368-1							
Clause	Requirement + Test				Result - Remark		Verdict
5.4.1.4, 9.3, B.1.5, B.2.6	TABLE: Temperature measurements						P
Supply voltage (V)	90V	264V	90V	264V	—		
Ambient temperature during test T_{amb} (°C).....:	See below	See below	See below	See below	—		
Maximum measured temperature T of part/at:	T (°C)				Allowed T_{max} (°C)		
--	1	1	2	2	--		
Plug holder(inside)	67.8	65.9	65.0	61.7	120		
LF1 coil	68.5	69.7	67.4	65.6	130		
L1 coil	82.2	74.7	77.4	70.0	130		
EC1 body	88.7	85.3	85.1	80.1	105		
EC2 body	83.8	79.4	79.9	74.4	105		
PCB near BD1	93.3	94.5	91.4	87.9	130		
PCB near Q1	92.7	101.9	88.3	94.5	130		
T1 coil	93.7	102.6	89.7	95.0	110		
T1 core	84.0	95.2	81.5	88.4	110		
PCB near Q2	84.0	100.4	81.8	91.2	125		
Inside enclosure near T1 top	75.0	85.0	74.6	80.3	120		
Outside enclosure near T1 top	50.5	41.9	53.1	56.3	77		
Ambient	25.0	25.0	25.0	25.0	--		
Temperature T of winding:	t_1 (°C)	R_1 (Ω)	t_2 (°C)	R_2 (Ω)	T (°C)	Allowed T_{max} (°C)	Insulation class
--	--	--	--	--	--	--	--
Supplementary information:							
1. Output load 20V1.65A							
2. Output load 5V4A							

IEC 62368-1								
Clause	Requirement + Test				Result - Remark			Verdict
B.2.5	TABLE: Input test							P
U (V)	Hz	I (A)	I rated (A)	P (W)	P rated (W)	Fuse No	I fuse (A)	Condition/status
90V	50	0.76	--	37.6	--	F1	0.76	Output load with 20V/1.65A
100V	50	0.69	1.1	37.3	--	F1	0.69	
240V	50	0.35	1.1	37.4	--	F1	0.35	
264V	50	0.34	1.1	37.6	--	F1	0.34	
90V	60	0.77	--	37.5	--	F1	0.77	
100V	60	0.70	1.1	37.2	--	F1	0.70	
240V	60	0.36	1.1	37.3	--	F1	0.36	
264V	60	0.35	1.1	37.5	--	F1	0.35	
90V	50	0.48	--	22.3	--	F1	0.48	Output load with 5V4A
100V	50	0.43	--	22.2	--	F1	0.43	
240V	50	0.21	1.1	22.1	--	F1	0.21	
264V	50	0.19	1.1	22.2	--	F1	0.19	
90V	60	0.49	1.1	21.2	--	F1	0.49	
100V	60	0.44	1.1	21.1	--	F1	0.44	
240V	60	0.22	--	21.1	--	F1	0.22	
264V	60	0.20	--	21.2	--	F1	0.20	
Supplementary information:								

IEC 62368-1			
Clause	Requirement + Test	Result - Remark	Verdict

B.3, B.4		TABLE: Abnormal operating and fault condition tests						P
Ambient temperature T_{amb} (°C)..... :						25°C unless otherwise specified		—
Power source for EUT: Manufacturer, model/type, outputrating.. :						-		—
Component No.	Condition	Supply voltage (V)	Test time	Fuse no.	Fuse current (A)	T-couple	Temp. (°C)	Observation
USB-C Output 20V	Overload	264Vac/60Hz	5hours	F1	0.36	T1 coil	107.3	Output shutdown at output 1.75A. No hazards. Measured touch current: 0.20mA _{peak}
						T1 core	99.3	
						Outside enclosure near T1	60.3	
						Ambient	25.0	
USB-C Output 5V	Overload	264Vac/60Hz	2hours	F1	0.19	T1 coil	99.2	Output shutdown at output 4.1A. No hazards. Measured touch current: 0.20mA _{peak}
						T1 core	91.1	
						Outside enclosure near T1	57.2	
						Ambient	25.0	
Transformer	Overload	264Vac/60Hz	5hours	F1	0.37	T1 coil	110.7	Output shutdown at output 4.1A. No hazards. Measured touch current: 0.20mA _{peak}
						T1 core	104.2	
						Outside enclosure near T1	62.5	
						Ambient	25.0	
BD1	shorted	264Vac/60Hz	1s	F1	0	--	--	Fuse opened immediately. No hazards. Measured touch current: 0.26mA _{peak}
Q1 pin D-S	shorted	264Vac/60Hz	1s	F1	0	--	--	Fuse opened immediately. No hazards. Measured touch current: 0.26mA _{peak}

IEC 62368-1								
Clause	Requirement + Test				Result - Remark			Verdict
Q1 pin D-G	shorted	264Vac/60Hz	1s	F1	0	--	--	Fuse opened immediately. No hazards. Measured touch current: 0.26mApeak
Q1 pin S-G	shorted	264Vac/60Hz	10mins	F1	0.02	--	--	Unit shutdown immediately, No damaged, no hazards. Measured touch current: 0.20mApeak
EC1	shorted	264Vac/60Hz	1s	F1	0	--	--	Fuse opened immediately. No hazards. Measured touch current: 0.26mApeak
T1 pin 1-2	shorted	264Vac/60Hz	10mins	F1	0.02	--	--	Unit shutdown immediately, No damaged, no hazards. Measured touch current: 0.20mApeak
T1 pin 3-4	shorted	264Vac/60Hz	10mins	F1	0.02	--	--	Unit shutdown immediately, No damaged, no hazards. Measured touch current: 0.20mApeak
T1 pin A-B	shorted	264Vac/60Hz	10mins	F1	0.02	--	--	Unit shutdown immediately, No damaged, no hazards. Measured touch current: 0.20mApeak
U3 pin 1-2	shorted	264Vac/60Hz	10mins	F1	0.02	--	--	Unit shutdown immediately, No damaged, no hazards. Measured touch current: 0.20mApeak
U3 pin 3-4	shorted	264Vac/60Hz	10mins	F1	0.02	--	--	Unit shutdown immediately, No damaged, no hazards. Measured touch current: 0.20mApeak

IEC 62368-1								
Clause	Requirement + Test				Result - Remark			Verdict
U3 pin 3	opened	264Vac/60Hz	10mins	F1	0.02	--	--	Unit shutdown immediately, No damaged, no hazards. Measured touch current: 0.20mApeak
U3 pin 1	opened	264Vac/60Hz	10mins	F1	0.02	--	--	Unit shutdown immediately, No damaged, no hazards. Measured touch current: 0.20mApeak
EC4	shorted	264Vac/60Hz	10mins	F1	0.02	--	--	Unit shutdown immediately, No damaged, no hazards. Measured touch current: 0.20mApeak
Output	shorted	264Vac/60Hz	10mins	F1	0.02	--	--	Unit shutdown immediately, No damaged, no hazards. Measured touch current: 0.20mApeak
Supplementary information: SC= short circuit; OC= open circuit								

M.3	TABLE: Protection circuits for batteries provided within the equipment						N/A
Is it possible to install the battery in a reverse polarity position?		--				—	
Equipment Specification	Charging						
	Voltage (V)				Current (A)		
Manufacturer/type	Battery specification						
	Non-rechargeable batteries			Rechargeable batteries			
	Discharging current (A)	Unintentional charging current (A)	Charging		Discharging current (A)	Reverse charging current (A)	
			Voltage (V)	Current (A)			
	--	--	--	--	--	--	
Note: The tests of M.3.2 are applicable only when above appropriate data is not available.							
Specified battery temperature (°C)				--			
Component No.	Fault condition	Charge/discharge mode	Test time	Temp. (°C)	Current (A)	Voltage (V)	Observation

IEC 62368-1							
Clause	Requirement + Test				Result - Remark		Verdict
--	--	--	--	--	--	--	--
--	--	--	--	--	--	--	--
Supplementary information:							
M.4.2	TABLE: Charging safeguards for equipment containing a secondary lithium battery						N/A
Maximum specified charging voltage (V)					--	---	
Maximum specified charging current (A)					--	---	
Highest specified charging temperature (°C)					--	---	
Lowest specified charging temperature (°C)					--	---	
Battery manufacturer/type	Operating and fault condition	Measurement			Observation		
		Charging voltage (V)	Charging current (A)	Temp. (°C)			
--	--	--	--	--	--		
--	--	--	--	--	--		
Supplementary information:							

Q.1	TABLE: Circuits intended for interconnection with building wiring (LPS)						P	
Output Circuit	Condition	U _{oc} (V)	Time (s)	I _{sc} (A)		S (VA)		
				Meas.	Limit	Meas.	Limit	
USB-A Output 5V	Normal	5.03	--	3.50	8	15.89	100	
	Abnormal: R6 SC	0	--	0	8	0	100	
USB-A Output 9V	Normal	9.06	--	3.20	8	27.51	100	
	Abnormal: R6 SC	0	--	0	8	0	100	
USB-A Output 12V	Normal	12.09	--	2.80	8	32.77	100	
	Abnormal: R6 SC	0	--	0	8	0	100	
USB-A Output 20V	Normal	20.06	--	1.65	8	32.81	100	
	Abnormal: R6 SC	0	--	0	8	0	100	
USB-C Output 5V	Normal	5.03	--	3.50	8	16.23	100	
	Abnormal: R6 SC	0	--	0	8	0	100	
USB-C	Normal	9.06	--	3.30	8	28.42	100	

IEC 62368-1							
Clause	Requirement + Test			Result - Remark			Verdict
Output 9V	Abnormal: R6 SC	0	--	0	8	0	100
USB-C Output 12V	Normal	12.07	--	2.80	8	32.74	100
	Abnormal: R6 SC	0	--	0	8	0	100
USB-C Output 15V	Normal	15.11	--	2.30	8	33.81	100
	Abnormal: R6 SC	0	--	0	8	0	100
USB-C Output 20V	Normal	20.18	--	1.75	8	34.98	100
	Abnormal: R6 SC	0	--	0	8	0	100
Supplementary Information: S-C: Short-circuited; O-C: Open-circuited; O-L: Overloaded							

T.2, T.3, T.4, T.5	TABLE: Steady force test						P
Part/Location	Material	Thickness (mm)	Probe	Force (N)	Test Duration (s)	Observation	
Enclosure top	Plastic	See table 4.1.2	--	100	5	No crack, no hazard.	
Enclosure side	Plastic	See table 4.1.2	--	100	5	No crack, no hazard.	
Enclosure bottom	Plastic	See table 4.1.2	--	100	5	No crack, no hazard.	
Supplementary information:							

T.6, T.9	TABLE: Impact test				P
Location/part	Material	Thickness (mm)	Height (mm)	Observation	
Enclosure top	Plastic	See table 4.1.2	1300	No crack, no hazard.	
Enclosure side	Plastic	See table 4.1.2	1300	No crack, no hazard.	
Enclosure bottom	Plastic	See table 4.1.2	1300	No crack, no hazard.	
Supplementary information:					

T.7	TABLE: Drop test	P
-----	------------------	---

IEC 62368-1				
Clause	Requirement + Test	Result - Remark		Verdict
Location/part	Material	Thickness (mm)	Height (mm)	Observation
Enclosure top	Plastic	See table 4.1.2	1000	No crack, no hazard.
Enclosure side	Plastic	See table 4.1.2	1000	No crack, no hazard.
Enclosure bottom	Plastic	See table 4.1.2	1000	No crack, no hazard.
Supplementary information: *) See table 4.1.2				

IEC 62368-1					
Clause	Requirement + Test			Result - Remark	Verdict
T.8	TABLE: Stress relief test				P
Location/Part	Material	Thickness (mm)	Oven Temperature (°C)	Duration (h)	Observation
Enclosure	Plastic	See table 4.1.2	95	7	No shrinkage or distortion
Supplementary information: *) See table 4.1.2					

X	TABLE: Alternative method for determining minimum clearances distances			N/A
Clearance distanced between:	Peak of working voltage (V)	Required cl (mm)	Measured cl (mm)	
--	--	--	--	
Supplementary information:				

IEC 62368-1			
Clause	Requirement + Test	Result - Remark	Verdict

4.1.2	TABLE: Critical components information				P
Object / part No.	Manufacturer/ trademark	Type / model	Technical data	Standard	Mark(s) of conformity ¹
Plastic Enclosure	SABIC INNOVATIVE PLASTICS B V	945(GG)	V-0, 120°C, Min. thickness: 1.5mm	IEC60695-11-10, UL 94	UL
Plastic Enclosure	CHI MEI CORPORATION	PC-540	V-0. 80°C, Min. thickness: 1.5mm	IEC60695-11-10, UL 94	UL
PCB	CHERITH TECHNOLOGY (HK) CO LTD	302	V-0 ,130°C	UL 796	UL
-(Alternative)	Various	Various	V-0 or better, 130°C	UL 796	UL
Fuse(F1)	SHENZHEN LANSON ELECTRONICS CO LTD	2E-Serie(s)	T2A, 250VAC	IEC/EN 60127-1 IEC/EN 60127-3	VDE
-(Alternative)	XC ELECTRONICS(SHENZHEN) CORP LTD	2T	T2A.250VAC	IEC/EN 60127-1 IEC/EN 60127-3	VDE
Y Capacitor (CY1)	JYA-NAY CO., LTD.	JN series	400V, 1500 pF, 125° C, Y1 type	IEC/EN 60384-14	TUV R 50232059
-(Alternative)	DONGGUAN EASY-GATHER ELECTRONIC CO., LTD.	DCF	1500pF, 250VAC, 125° C, Y1 type	IEC60384-14	VDE
-(Alternative)	Various	Various	Max. 1500PF, AC400V, 125°C , Y1 type	IEC60384-14	VDE
Opto-Coupler	EVERLIGHT ELECTRONICS CO LTD	EL817	Int. cr. ≥5.0mm, ext. cr. ≥7.6mm, dti. ≥0.4mm, min. 110°C, Soldered on PWB.	EN60747-5-5 EN62368-1	UL
-(Alternative)	HUBEI KENTO ELECTRONIC CO LTD	JC817	Int. cr. ≥5.0mm, ext. cr. ≥7.6mm, dti. ≥0.4mm, min. 110°C, Soldered on PWB.	EN60747-5-5 EN62368-1	UL
Input lead wire	SHENZHEN JIAHUIDA ELECTRONICS CO LTD	3239	Min. 300V, VW-1, Min. 100°C, Min. 22AWG	UL 758	UL

IEC 62368-1					
Clause	Requirement + Test			Result - Remark	Verdict
4.1.2	TABLE: Critical components information				P
Object / part No.	Manufacturer/ trademark	Type / model	Technical data	Standard	Mark(s) of conformity ¹
-(Alternative)	SHENZHEN DINGYU ELECTRICAL TECHNOLOGY CO LTD	3239	Min. 300V, VW-1, Min. 100°C, Min. 22AWG	UL 758	UL
-(Alternative)	Interchangeable	3239	Min. 300V, VW-1, Min. 100°C, Min. 22AWG	UL 758	UL
Line filter (LF1)	Interchangeable	Interchangeable	130°C	EN62368-1	Tested with appliance
Transformer (T1)	SHENZHEN BOLIANG ELECTRONIC CO.,LTD	PQ2018-33W	Class B	EN62368-1	Tested with Appliance
Bobbin of T1.	SUMITOMO BAKELITE CO LTD	PM-8375	Phenolic, V-0, 150°C	UL 94	UL
Magnet Wire of T1.	SHANTOU SHENGANG ELECTRICAL INDUSTRIAL CO LTD	MW75/130	130°C	UL 1446	UL
Triple Insulated Wire of T1.	FURUKAWA ELECTRIC CO LTD	TEX-E	130°C	IEC/EN62368-1	VDE
Insulation Tape of T1.	JINGJIANG YAHUA PRESSURE SENSITIVE GLUE CO LTD	PZ*(b)	130°C	UL 510A	UL
Insulation tube of T1 .	GREAT HOLDING INDUSTRIAL CO LTD	TFL	200°C	UL 224	UL
Varnish of T1.	JOHN C DOLPH CO	BC-346A	200°C	UL1446	UL

National Differences			
Clause	Requirement + Test	Result - Remark	Verdict

ATTACHMENT TO TEST REPORT IEC 62368-1 EUROPEAN GROUP DIFFERENCES AND NATIONAL DIFFERENCES (Audio/video, information and communication technology equipment - Part 1: Safety requirements)
--

CENELEC COMMON MODIFICATIONS (EN)																																						
	Clauses, subclauses, notes, tables, figures and annexes which are additional to those in IEC 62368-1:2014 are prefixed "Z".	P																																				
CONTENTS	Add the following annexes: Annex ZA (normative) Normative references to international publications with their corresponding European publications Annex ZB (normative) Special national conditions Annex ZC (informative) A-deviations Annex ZD (informative) IEC and CENELEC code designations for flexible cords	P																																				
	Delete all the "country" notes in the reference document (IEC 62368-1:2014) according to the following list: <table border="1" data-bbox="343 958 1275 1393"> <tbody> <tr> <td>0.2.1</td> <td>Note</td> <td>1</td> <td>Note 3</td> <td>4.1.15</td> <td>Note</td> </tr> <tr> <td>4.7.3</td> <td>Note 1 and 2</td> <td>5.2.2.2</td> <td>Note</td> <td>5.4.2.3.2.2 Table 13</td> <td>Note c</td> </tr> <tr> <td>5.4.2.3.2.4</td> <td>Note 1 and 3</td> <td>5.4.2.5</td> <td>Note 2</td> <td>5.4.5.1</td> <td>Note</td> </tr> <tr> <td>5.5.2.1</td> <td>Note</td> <td>5.5.6</td> <td>Note</td> <td>5.6.4.2.1</td> <td>Note 2 and 3</td> </tr> <tr> <td>5.7.5</td> <td>Note</td> <td>5.7.6.1</td> <td>Note 1 and 2</td> <td>10.2.1 Table 39</td> <td>Note 2, 3 and 4</td> </tr> <tr> <td>10.5.3</td> <td>Note 2</td> <td>10.6.2.1</td> <td>Note 3</td> <td>F.3.3.6</td> <td>Note 3</td> </tr> </tbody> </table>	0.2.1	Note	1	Note 3	4.1.15	Note	4.7.3	Note 1 and 2	5.2.2.2	Note	5.4.2.3.2.2 Table 13	Note c	5.4.2.3.2.4	Note 1 and 3	5.4.2.5	Note 2	5.4.5.1	Note	5.5.2.1	Note	5.5.6	Note	5.6.4.2.1	Note 2 and 3	5.7.5	Note	5.7.6.1	Note 1 and 2	10.2.1 Table 39	Note 2, 3 and 4	10.5.3	Note 2	10.6.2.1	Note 3	F.3.3.6	Note 3	P
0.2.1	Note	1	Note 3	4.1.15	Note																																	
4.7.3	Note 1 and 2	5.2.2.2	Note	5.4.2.3.2.2 Table 13	Note c																																	
5.4.2.3.2.4	Note 1 and 3	5.4.2.5	Note 2	5.4.5.1	Note																																	
5.5.2.1	Note	5.5.6	Note	5.6.4.2.1	Note 2 and 3																																	
5.7.5	Note	5.7.6.1	Note 1 and 2	10.2.1 Table 39	Note 2, 3 and 4																																	
10.5.3	Note 2	10.6.2.1	Note 3	F.3.3.6	Note 3																																	
	For special national conditions, see Annex ZB.	--																																				
1	Add the following note: NOTE Z1 The use of certain substances in electrical and electronic equipment is restricted within the EU: see Directive 2011/65/EU.	N/A																																				

National Differences			
Clause	Requirement + Test	Result - Remark	Verdict
4.Z1	<p>Add the following new subclause after 4.9:</p> <p>To protect against excessive current, short-circuits and earth faults in circuits connected to an a.c. mains, protective devices shall be included either as integral parts of the equipment or as parts of the building installation, subject to the following, a), b) and c):</p> <p>a) except as detailed in b) and c), protective devices necessary to comply with the requirements of B.3.1 and B.4 shall be included as parts of the equipment;</p> <p>b) for components in series with the mains input to the equipment such as the supply cord, appliance coupler, r.f.i. filter and switch, short-circuit and earth fault protection may be provided by protective devices in the building installation;</p> <p>c) it is permitted for pluggable equipment type B or permanently connected equipment, to rely on dedicated overcurrent and short-circuit protection in the building installation, provided that the means of protection, e.g. fuses or circuit breakers, is fully specified in the installation instructions.</p> <p>If reliance is placed on protection in the building installation, the installation instructions shall so state, except that for pluggable equipment type A the building installation shall be regarded as providing protection in accordance with the rating of the wall socket outlet.</p>	Considered.	P
5.4.2.3.2.4	<p>Add the following to the end of this subclause:</p> <p>The requirement for interconnection with external circuit is in addition given in EN 50491-3:2009.</p>	No connection to external circuit.	N/A
10.2.1	<p>Add the following to ^{c)} and ^{d)} in table 39:</p> <p>For additional requirements, see 10.5.1.</p>	No radiation.	N/A

National Differences			
Clause	Requirement + Test	Result - Remark	Verdict
10.5.1	<p>Add the following after the first paragraph: <i>For RS 1 compliance is checked by measurement under the following conditions: In addition to the normal operating conditions, all controls adjustable from the outside by hand, by any object such as a tool or a coin, and those internal adjustments or presets which are not locked in a reliable manner, are adjusted so as to give maximum radiation whilst maintaining an intelligible picture for 1 h, at the end of which the measurement is made.</i></p> <p>NOTE Z1 Soldered joints and paint lockings are examples of adequate locking. <i>The dose-rate is determined by means of a radiation monitor with an effective area of 10 cm², at any point 10 cm from the outer surface of the apparatus.</i></p> <p><i>Moreover, the measurement shall be made under fault conditions causing an increase of the high-voltage, provided an intelligible picture is maintained for 1 h, at the end of which the measurement is made.</i></p> <p><i>For RS1, the dose-rate shall not exceed 1 μSv/h taking account of the background level.</i></p> <p>NOTE Z2 These values appear in Directive 96/29/Euratom of 13 May 1996.</p>	Added.	N/A
10.6.1	<p>Add the following paragraph to the end of the subclause: EN 71-1:2011, 4.20 and the related tests methods and measurement distances apply.</p>	Added.	N/A
10.Z1	<p>Add the following new subclause after 10.6.5. 10.Z1 Non-ionizing radiation from radio frequencies in the range 0 to 300 GHz The amount of non-ionizing radiation is regulated by European Council Recommendation 1999/519/EC of 12 July 1999 on the limitation of exposure of the general public to electromagnetic fields (0 Hz to 300 GHz).</p> <p>For intentional radiators, ICNIRP guidelines should be taken into account for Limiting Exposure to Time-Varying Electric, Magnetic, and Electromagnetic Fields (up to 300 GHz). For hand-held and body-mounted devices, attention is drawn to EN 50360 and EN 50566</p>		N/A
G.7.1	<p>Add the following note: NOTE Z1 The harmonized code designations corresponding to the IEC cord types are given in Annex ZD.</p>	Added.	N/A

National Differences			
Clause	Requirement + Test	Result - Remark	Verdict
Bibliography	<p>Add the following standards:</p> <p>Add the following notes for the standards indicated:</p> <p>IEC 60130-9 NOTE Harmonized as EN 60130-9.</p> <p>IEC 60269-2 NOTE Harmonized as HD 60269-2.</p> <p>IEC 60309-1 NOTE Harmonized as EN 60309-1.</p> <p>IEC 60364 NOTE some parts harmonized in HD 384/HD 60364 series.</p> <p>IEC 60601-2-4 NOTE Harmonized as EN 60601-2-4.</p> <p>IEC 60664-5 NOTE Harmonized as EN 60664-5.</p> <p>IEC 61032:1997 NOTE Harmonized as EN 61032:1998 (not modified).</p> <p>IEC 61508-1 NOTE Harmonized as EN 61508-1.</p> <p>IEC 61558-2-1 NOTE Harmonized as EN 61558-2-1.</p> <p>IEC 61558-2-4 NOTE Harmonized as EN 61558-2-4.</p> <p>IEC 61558-2-6 NOTE Harmonized as EN 61558-2-6.</p> <p>IEC 61643-1 NOTE Harmonized as EN 61643-1.</p> <p>IEC 61643-21 NOTE Harmonized as EN 61643-21.</p> <p>IEC 61643-311 NOTE Harmonized as EN 61643-311.</p> <p>IEC 61643-321 NOTE Harmonized as EN 61643-321.</p> <p>IEC 61643-331 NOTE Harmonized as EN 61643-331.</p>		N/A
ZB	ANNEX ZB, SPECIAL NATIONAL CONDITIONS (EN)		--
4.1.15	<p>Denmark, Finland, Norway and Sweden</p> <p>To the end of the subclause the following is added:</p> <p>Class I pluggable equipment type A intended for connection to other equipment or a network shall, if safety relies on connection to reliable earthing or if surge suppressors are connected between the network terminals and accessible parts, have a marking stating that the equipment shall be connected to an earthed mains socket-outlet.</p> <p>The marking text in the applicable countries shall be as follows:</p> <p>In Denmark: "Apparatets stikprop skal tilsluttes en stikkontakt med jord som giver forbindelse til stikproppens jord."</p> <p>In Finland: "Laitte on liitettävä suojakoskettimilla varustettuun pistorasiaan"</p> <p>In Norway: "Apparatet må tilkoples jordet stikkontakt"</p> <p>In Sweden: "Apparaten skall anslutas till jordat uttag"</p>	Class II equipment.	N/A

National Differences			
Clause	Requirement + Test	Result - Remark	Verdict
4.7.3	<p>United Kingdom</p> <p>To the end of the subclause the following is added:</p> <p>The torque test is performed using a socket-outlet complying with BS 1363, and the plug part shall be assessed to the relevant clauses of BS 1363. Also see Annex G.4.2 of this annex</p>		N/A
5.2.2.2	<p>Denmark</p> <p>After the 2nd paragraph add the following:</p> <p>A warning (marking safeguard) for high touch current is required if the touch current exceeds the limits of 3,5 mA a.c. or 10 mA d.c.</p>	No high touch current measured.	N/A

National Differences			
Clause	Requirement + Test	Result - Remark	Verdict
5.4.11.1 and Annex G	<p>Finland and Sweden</p> <p>To the end of the subclause the following is added:</p> <p>For separation of the telecommunication network from earth the following is applicable:</p> <p>If this insulation is solid, including insulation forming part of a component, it shall at least consist of either</p> <ul style="list-style-type: none"> • two layers of thin sheet material, each of which shall pass the electric strength test below, or • one layer having a distance through insulation of at least 0,4 mm, which shall pass the electric strength test below. <p>If this insulation forms part of a semiconductor component (e.g. an optocoupler), there is no distance through insulation requirement for the insulation consisting of an insulating compound completely filling the casing, so that clearances and creepage distances do not exist, if the component passes the electric strength test in accordance with the compliance clause below and in addition</p> <ul style="list-style-type: none"> • passes the tests and inspection criteria of 5.4.8 with an electric strength test of 1,5 kV multiplied by 1,6 (the electric strength test of 5.4.9 shall be performed using 1,5 kV), and • is subject to routine testing for electric strength during manufacturing, using a test voltage of 1,5kV. <p>It is permitted to bridge this insulation with a capacitor complying with EN 60384-14:2005, subclass Y2.</p> <p>A capacitor classified Y3 according to EN 60384-14:2005, may bridge this insulation under the following conditions:</p> <ul style="list-style-type: none"> • the insulation requirements are satisfied by having a capacitor classified Y3 as defined by EN 60384-14, which in addition to the Y3 testing, is tested with an impulse test of 2,5 kV defined in 5.4.11; • the additional testing shall be performed on all the test specimens as described in EN 60384-14; <p>the impulse test of 2,5 kV is to be performed before the endurance test in EN 60384-14, in the sequence of tests as described in EN 60384-14.</p>	No connection to such a network.	N/A

National Differences			
Clause	Requirement + Test	Result - Remark	Verdict
5.5.2.1	<p>Norway</p> <p>After the 3rd paragraph the following is added: Due to the IT power system used, capacitors are required to be rated for the applicable line-to-line voltage (230 V).</p>	Considered.	P
5.5.6	<p>Finland, Norway and Sweden</p> <p>To the end of the subclause the following is added: Resistors used as basic safeguard or bridging basic insulation in class I pluggable equipment type A shall comply with G.10.1 and the test of G.10.2.</p>	No such resistor used.	N/A
5.6.1	<p>Denmark</p> <p>Add to the end of the subclause Due to many existing installations where the socket-outlets can be protected with fuses with higher rating than the rating of the socket-outlets the protection for pluggable equipment type A shall be an integral part of the equipment. <i>Justification:</i> In Denmark an existing 13 A socket outlet can be protected by a 20 A fuse.</p>	Added.	N/A
5.6.4.2.1	<p>Ireland and United Kingdom</p> <p>After the indent for pluggable equipment type A, the following is added: – the protective current rating is taken to be 13 A, this being the largest rating of fuse used in the mains plug.</p>	Added.	N/A
5.6.5.1	<p>To the second paragraph the following is added: The range of conductor sizes of flexible cords to be accepted by terminals for equipment with a rated current over 10 A and up to and including 13 A is: 1,25 mm² to 1,5 mm² in cross-sectional area.</p>		N/A
5.7.5	<p>Denmark</p> <p>To the end of the subclause the following is added: The installation instruction shall be affixed to the equipment if the protective conductor current exceeds the limits of 3,5 mA a.c. or 10 mA d.c.</p>		N/A

National Differences			
Clause	Requirement + Test	Result - Remark	Verdict
5.7.6.1	<p>Norway and Sweden</p> <p>To the end of the subclause the following is added: The screen of the television distribution system is normally not earthed at the entrance of the building and there is normally no equipotential bonding system within the building. Therefore the protective earthing of the building installation needs to be isolated from the screen of a cable distribution system.</p> <p>It is however accepted to provide the insulation external to the equipment by an adapter or an interconnection cable with galvanic isolator, which may be provided by a retailer, for example.</p> <p>The user manual shall then have the following or similar information in Norwegian and Swedish language respectively, depending on in what country the equipment is intended to be used in: "Apparatus connected to the protective earthing of the building installation through the mains connection or through other apparatus with a connection to protective earthing – and to a television distribution system using coaxial cable, may in some circumstances create a fire hazard. Connection to a television distribution system therefore has to be provided through a device providing electrical isolation below a certain frequency range (galvanic isolator, see EN 60728-11)"</p> <p>NOTE In Norway, due to regulation for CATV-installations, and in Sweden, a galvanic isolator shall provide electrical insulation below 5 MHz. The insulation shall withstand a dielectric strength of 1,5 kV r.m.s., 50 Hz or 60 Hz, for 1 min.</p> <p>Translation to Norwegian (the Swedish text will also be accepted in Norway):</p> <p>"Apparater som er koplet til beskyttelsesjord via nettplugg og/eller via annet jordtilkoplet utstyr – og er tilkoplet et koaksialbasert kabel-TV nett, kan forårsake brannfare. For å unngå dette skal det ved tilkopling av apparater til kabel-TV nett installeres en galvanisk isolator mellom apparatet og kabel-TV nettet."</p> <p>Translation to Swedish: "Apparater som är kopplad till skyddsjord via jordat vägguttag och/eller via annan utrustning och samtidigt är kopplad till kabel-TV nät kan i vissa fall medföra risk för brand. För att undvika detta skall vid anslutning av apparaten till kabel-TV nät galvanisk isolator finnas mellan apparaten och kabel-TV nätet."</p>		N/A

National Differences			
Clause	Requirement + Test	Result - Remark	Verdict
5.7.6.2	<p>Denmark</p> <p>To the end of the subclause the following is added:</p> <p>The warning (marking safeguard) for high touch current is required if the touch current or the protective current exceed the limits of 3,5 mA .</p>		N/A
B.3.1 and B.4	<p>Ireland and United Kingdom</p> <p>The following is applicable:</p> <p>To protect against excessive currents and short-circuits in the primary circuit of direct plug-in equipment, tests according to Annexes B.3.1 and B.4 shall be conducted using an external miniature circuit breaker complying with EN 60898-1, Type B, rated 32A. If the equipment does not pass these tests, suitable protective devices shall be included as an integral part of the direct plug-in equipment, until the requirements of Annexes B.3.1 and B.4 are met</p>		P

National Differences			
Clause	Requirement + Test	Result - Remark	Verdict
G.4.2	<p>Denmark</p> <p>To the end of the subclause the following is added:</p> <p>Supply cords of single phase appliances having a rated current not exceeding 13 A shall be provided with a plug according to DS 60884-2-D1:2011.</p> <p>CLASS I EQUIPMENT provided with socket-outlets with earth contacts or which are intended to be used in locations where protection against indirect contact is required according to the wiring rules shall be provided with a plug in accordance with standard sheet DK 2-1a or DK 2-5a.</p> <p>If a single-phase equipment having a RATED CURRENT exceeding 13 A or if a poly-phase equipment is provided with a supply cord with a plug, this plug shall be in accordance with the standard sheets DK 6-1a in DS 60884-2-D1 or EN 60309-2.</p> <p>Mains socket outlets intended for providing power to Class II apparatus with a rated current of 2,5 A shall be in accordance DS 60884-2-D1:2011 standard sheet DKA 1-4a.</p> <p>Other current rating socket outlets shall be in compliance with Standard Sheet DKA 1-3a or DKA 1-1c.</p> <p>Mains socket-outlets with earth shall be in compliance with DS 60884-2-D1:2011 Standard Sheet DK 1-3a, DK 1-1c, DK1-1d, DK 1-5a or DK 1-7a</p> <p><i>Justification:</i> Heavy Current Regulations, Section 6c</p>		N/A
G.4.2	<p>United Kingdom</p> <p>To the end of the subclause the following is added:</p> <p>The plug part of direct plug-in equipment shall be assessed to BS 1363: Part 1, 12.1, 12.2, 12.3, 12.9, 12.11, 12.12, 12.13, 12.16, and 12.17, except that the test of 12.17 is performed at not less than 125 °C. Where the metal earth pin is replaced by an Insulated Shutter Opening Device (ISOD), the requirements of clauses 22.2 and 23 also apply.</p>		P

National Differences			
Clause	Requirement + Test	Result - Remark	Verdict
G.7.1	<p>United Kingdom</p> <p>To the first paragraph the following is added: Equipment which is fitted with a flexible cable or cord and is designed to be connected to a mains socket conforming to BS 1363 by means of that flexible cable or cord shall be fitted with a 'standard plug' in accordance with the Plugs and Sockets etc (Safety) Regulations 1994, Statutory Instrument 1994 No. 1768, unless exempted by those regulations.</p> <p>NOTE "Standard plug" is defined in SI 1768:1994 and essentially means an approved plug conforming to BS 1363 or an approved conversion plug.</p>		P
G.7.1	<p>Ireland</p> <p>To the first paragraph the following is added: Apparatus which is fitted with a flexible cable or cord shall be provided with a plug in accordance with Statutory Instrument 525: 1997, "13 A Plugs and Conversion Adapters for Domestic Use Regulations: 1997. S.I. 525 provides for the recognition of a standard of another Member State which is equivalent to the relevant Irish Standard</p>		N/A
G.7.2	<p>Ireland and United Kingdom</p> <p>To the first paragraph the following is added: A power supply cord with a conductor of 1,25 mm² is allowed for equipment which is rated over 10 A and up to and including 13 A.</p>		N/A
ZC	ANNEX ZC, NATIONAL DEVIATIONS (EN)		--
10.5.2	<p>Germany</p> <p>The following requirement applies: For the operation of any cathode ray tube intended for the display of visual images operating at an acceleration voltage exceeding 40 kV, authorization is required, or application of type approval (Bauartzulassung) and marking.</p> <p><i>Justification:</i> German ministerial decree against ionizing radiation (Röntgenverordnung), in force since 2002-07-01, implementing the European Directive 96/29/EURATOM.</p> <p>NOTE Contact address: Physikalisch-Technische Bundesanstalt, Bundesallee 100, D-38116 Braunschweig, Tel.: Int +49-531-592-6320, Internet: http://www.ptb.de</p>	Not such equipment.	N/A

National Differences			
Clause	Requirement + Test	Result - Remark	Verdict
ATTACHMENT TO TEST REPORT IEC 62368-1 (DENMARK) NATIONAL DIFFERENCES Audio/video, information and communication technology equipment – Part 1: Safety requirements			
Differences according to		DS/EN 62368-1:2014	
Attachment Form No.....		DK_ND_IEC62368_1B	
Attachment Originator		UL (Demko)	
Master Attachment.....		2014-10	
Copyright © 2014 IEC System for Conformity Testing and Certification of Electrical Equipment (IECEE), Geneva, Switzerland. All rights reserved.			

National Differences			
4.1.15	<p>To the end of the subclause the following is added:</p> <p>Class I pluggable equipment type A intended for connection to other equipment or a network shall, if safety relies on connection to reliable earthing or if surge suppressors are connected between the network terminals and accessible parts, have a marking stating that the equipment shall be connected to an earthed mains socket-outlet.</p> <p>The marking text in the applicable countries shall be as follows: “Apparatets stikprop skal tilsluttes en stikkontakt med jord som giver forbindelse til stikproppens jord.”</p>		N/A
5.2.2.2	<p>After the 2nd paragraph add the following: A warning (marking safeguard) for high touch current is required if the touch current exceeds the limits of 3,5 mA a.c. or 10 mA d.c.</p>		N/A
5.6.1	<p>Add to the end of the subclause:</p> <p>Due to many existing installations where the socket-outlets can be protected with fuses with higher rating than the rating of the socket-outlets the protection for pluggable equipment type A shall be an integral part of the equipment.</p> <p>Justification: In Denmark an existing 13 A socket outlet can be protected by a 20 A fuse.</p>		N/A
5.7.5	<p>To the end of the subclause the following is added: The installation instruction shall be affixed to the equipment if the protective conductor current exceeds the limits of 3,5 mA a.c. or 10 mA d.c.</p>		N/A

National Differences			
Clause	Requirement + Test	Result - Remark	Verdict
5.7.6.2	<p>To the end of the subclause the following is added:</p> <p>The warning (marking safeguard) for high touch current is required if the touch current or the protective current exceed the limits of 3,5 mA.</p>		N/A
G.4.2	<p>To the end of the subclause the following is added:</p> <p>Supply cords of single phase appliances having a rated current not exceeding 13 A shall be provided with a plug according to DS 60884-2-D1:2011.</p> <p>CLASS I EQUIPMENT provided with socket-outlets with earth contacts or which are intended to be used in locations where protection against indirect contact is required according to the wiring rules shall be provided with a plug in accordance with standard sheet DK 2-1a or DK 2-5a.</p> <p>If a single-phase equipment having a RATED CURRENT exceeding 13 A or if a poly-phase equipment is provided with a supply cord with a plug, this plug shall be in accordance with the standard sheets DK 6-1a in DS 60884-2-D1 or EN 60309-2.</p> <p>Mains socket outlets intended for providing power to Class II apparatus with a rated current of 2,5 A shall be in accordance DS 60884-2-D1:2011 standard sheet DKA 1-4a.</p> <p>Other current rating socket outlets shall be in compliance with Standard Sheet DKA 1-3a or DKA 1-1c.</p> <p>Mains socket-outlets with earth shall be in compliance with DS 60884-2-D1:2011 Standard Sheet DK 1-3a, DK 1-1c, DK1-1d, DK 1-5a or DK 1-7a</p> <p>Justification: Heavy Current Regulations, Section 6c</p>		N/A

EN 50075 (partially)

Clause	Requirement + Test	Result - Remark	Verdict
--------	--------------------	-----------------	---------

6	Marking		P
	Appliances shall be marked as follows:	No additional marking required, plug is part of direct plug-in adaptor enclosure.	—
	Rated current in amperes (A)	Refer to marking label of final appliance.	N
	Rated Voltage in volts (V)	As above	N
	Symbol for nature of supply (~)	As above	N
	Name, trade mark or identification mark of manufacturer or responsible vendor		P
	Type reference	Incorporated plug portion of adaptor	P

7	Dimensions		P	
	Plugs shall comply with Standard Sheet 1	(see attached drawing)	—	
	Between two pins (pin base)	18.0 - 19.2 mm	18.36 mm	P
	Between two pins (pin top)	17.0 - 18.0 mm	17.90 mm	P
	Diameter of pin (metallic part)	4 ±0.06 mm	3.98 mm	P
	Diameter of pin (pin base)	max. 4.0 mm	3.99 mm	P
	Diameter of pin (middle part)	max. 3.8 mm	3.55 mm	P
	Pin length	19 ±0.5 mm	19.43 mm	P
	Length of pin except metal part	10 +1/-0 mm	10.76 mm	P
	Shape of pin top		round shape	P
	Length of plug base	35.3 ±0.7 mm	35.21 mm	P
	Width of plug base	13.7 ±0.7 mm	13.90 mm	P
	Diagonal dimension of plug base	26.1 ±0.5 mm	26.10 mm	P
	Height of plug projection part	≥ 18 mm	19.11 mm	P
	Angle	45°	45 °	P
	Radius	R 5 -0, +1 mm	5.09 mm	P

8.	Protection against electric shock		P
8.1	Live parts of the plug not accessible (standard test finger)	Protected by enclosure of the equipment	P

EN 50075 (partially)			
Clause	Requirement + Test	Result - Remark	Verdict
8.2	No connection between one plug-pin and socket outlet	Checked by gauge of Fig.4	P
8.3	External parts of insulating material	External parts except pins are insulating material.	P
9	Construction		P
9.1	Plugs not replaceable	Not replaceable	P
9.2	Switches, fuses, lampholders not incorporated	Not incorporated	P
9.3	Solid pins	(see clause 13)	P
	Adequate mechanical strength	As above	P
9.4	Pins locked against rotation	No displacement or rotation visible.	P
	Adequate fixed into the body	Each pin shaft is designed with ridges to lock into the pin holder	P
9.5	Kind of connection	Leads are hooked and soldered to the plug pin terminal.	P
9.6	Easily to be withdrawn from socket-outlet	The equipment provides sufficient gripping surface	P
10	Resistance to humidity		P
	-Humidity treatment for 48 hours	Tested with the equipment for 48h at 30°C and 93% RH	P
11	Insulation resistance and electric strength		P
11.1	Insulation resistance (500 V, min 5 MΩ)	Pins against body: 100MΩ Each pin against body: 100MΩ Required: 8MΩ Pin against Pin: 100MΩ Required: 3MΩ	P
11.2	Electric strength (2,000 V)	Pins against body: 4,200V Each pin against body: 4,200V Pin against Pin: 2,100V	P
13	Mechanical strength		P
13.1	Pressed with 150 N for 5 min	No deformation or deviation from the dimensions	P

EN 50075 (partially)			
Clause	Requirement + Test	Result - Remark	Verdict
13.2	Tumbling barrel according to Figure 8	Test was performed on equipment according to Figure 8 of this standard. Number of falls: 500 times	P
	No damages after the test		P
	Requirements of clause 7 and 8.2 still fulfilled	Deformations allowed according to the equipment standard	P
13.3	Rubbing test of plug-pins: 10,000 cycles, 4 N	See test below	P
	No damage of the pins	No visible damage	P
13.4	Pull test at 70°C with 40 N	See test below	P
	Pins not more than 1 mm displaced	Displacement: 0.2mm	P
14	Resistance to heat and to ageing		P
14.1	Sufficient resistant to heat	See test below	P
14.1.1	After 1 h in heating cabinet at 100°C no damage shown	No visible damage	P
14.1.2	After 1h in heating cabinet at 80°C and a force of 20 N through the jaws no damage shown	Performed a 125°C ball pressure test at the material of plug portion which maintains live part in position. 0.83 mm measured after 1 hour	P
14.2	Aging test	See test below	P
	- at 70°C for 168h	70°C for 168h applied.	P
	- at room temperature for 96h		N
	No traces of cloth at a force of 5N	Material does not soften	P
	No damage leads to non-compliance	No visible damage	P
15	Current-carrying parts and connections resistance to heat and to ageing		P
15.1	Connections withstand the mechanical stresses occurring in normal use	See below	P
15.2	Contact pressure not through isolating material	Complied	P
15.3	Current carrying parts of copper	Copper content: 63.8% No rolled sheet used	P
	No electroplated coating when part is subjected to mechanical wear	No electroplated coating	P
	Other metals having a mechanical strength, an electrical conductivity and a resistance to corrosion	No such materials used.	N

EN 50075 (partially)			
Clause	Requirement + Test	Result - Remark	Verdict
16	Creepage distances , clearances and distances through insulation		P
	Live parts of different polarity: 3 mm	>3mm	P
	Through insulation between live parts and accessible surfaces: 1.5 mm	Min 1.54mm	P
17	Resistance of insulating material to abnormal heat and fire		P
	Insulating material not unduly affected by abnormal heat and by fire	Glow wire test performed on plug holder with: 750°C	P
	Other parts	650°C	P
7	Dimensions		P

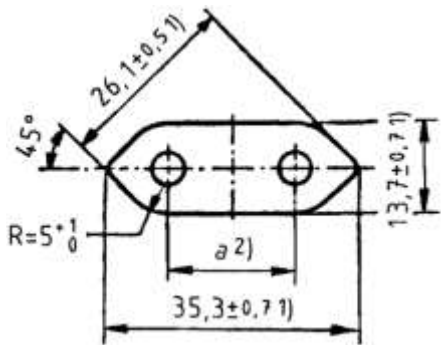

Alternative for end of pins

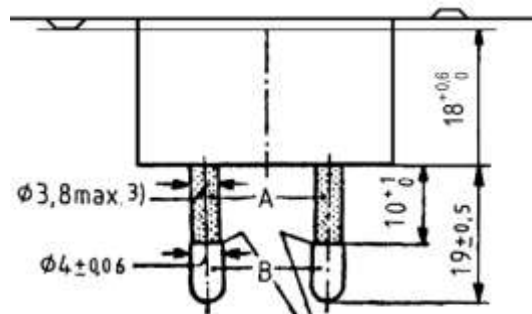
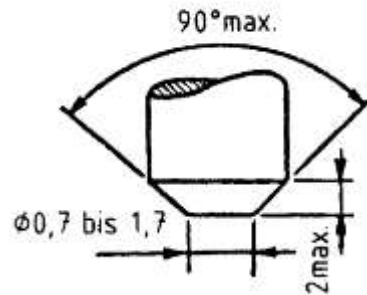

The edges of the metal parts shall be either chamfered or rounded off

A = Insulating collar
B = metal pin

- 1) These dimensions shall not be exceeded within a distance of 18mm from the engagement face of the plug.
- 2) Dimension a is:
18mm to 19.2mm in the plane of the engagement face
17mm to 18mm at the ends of the pins
- 3) This dimension may be increased to 4mm within a distance of 4mm from the engagement face of the plug.

BS 1363-1			
Clause	Requirement + Test	Result - Remark	Verdict
12	Construction of Plugs		P
12.1	The disposition of the pins shall be shown as figure 4.	The dispositions of the pins were shown as specified.	P
12.2	Pin and sleeve dimensions, body outline were checked according to figure 4 of BS1363: part 1.	The outline of the plug did not exceed the specified dimensions at a distance of 8.96mm from the engagement surface. (limit: >6.35mm) The measured dimensions of item shown in fig. 4 were found within the specified limits.	P
	The plug portion should enter the gauge fully with a force less than 10N was applied to the centre of the sample at right angle.	Sample was entered into the gauge completely.	P
12.3	No part of a line or neutral pin shall be less than 9,5mm from the periphery of the plug measured along the engagement surface.	9.78mm	P
12.9	Plug pins were constructed of brass	Complied.	P
12.9.1	Exposed surface of plug pins were smooth and free from burrs or sharp edges and other irregularities, which could cause damage or excessive wear to sockets or shutters.	Complied.	P
12.9.4	The adaptor plug pins were tested as specified in the standard.	Complied. After being subjected to a force of 1100N for L, N pin, 400N for ISOD pin, the pin portion could fit the relevant gauge.	P
12.9.6	Each pin of the adaptor was subjected to a torque of 1Nm for 60s as specified in the standard.	Complied. After the test, the pin portion could fit the relevant gauge.	P
12.11	The adaptors were tested as specified in the standard. After being placed in an oven at 70°C for 1 hour, each pin of the samples was subjected for 60 sec. to a pull of 100N in the oven.	Complied. After the above test, no plug pin was detached and the plug pins could fit the relevant gauge.	P
12.12	The degree of flexibility of mounting of the plug pins was checked according to 12.12.1	Measured value: Max. 1.25° (test on each sources of enclosure, max. value measured) (limit: Max. 3° 30').	P
12.16	Line and neutral plug pin shall be fitted with insulating sleeves. The dimensions of the pin and sleeve shall fall within the specific limit.	Complied. Both line and neutral pins were fitted with insulating sleeves.	P
12.17.1	Plug pin sleeve shall be compliance with 12.17.2 to 12.17.4	Complied.	P

BS 1363-1			
Clause	Requirement + Test	Result - Remark	Verdict
12.17.2	Electric strength test applied between the metal part of plug pin and the sleeve (1250±30V)	Complied. No breakdown or flashover occurs.	P
12.17.3	Abrasion test for plug pin sleeve The plug pin sleeves were subjected to 20000 movements of abrasion as specified in the standard.	Complied. After the test, the sleeves showed no damage that impaired further use and could satisfy the electric strength test in 12.17. 2	P
12.17.4	The plug pins with sleeves were placed in a heating cabinet at 200°C and tested according to the standard for 120min. Arrange the test as Figure 10 of BS 1363-1.	After the test, the thickness of sleeves of plug pins (Line and neutral pins) remaining at the impression point reduced by max. 12.34% less than 50%.	P

ADDITIONAL REQUIREMENT FOR THE SOLID INSULATED SHUTTER OPENING DEVICE (ISOD)

12.2	Plug fitted with an ISOD shall comply with all the dimensions specified in Fig. 4a with exception of the width of the ISOD, which should be 4,05mm max. and 3,90mm min. and its height which should be 8,05mm max. and 7,75mm min.	See measured dimensions in Table 3	P
12.9.4.3	Solid insulated opening device were tested as specified in the standard.	After being subjected to a forced of 400N, the pin could fit the relevant gauge.	P
12.9.5.2	Plugs with ISOD shall not cause excessive wear to socket contacts or shutters of sockets-outlets The test use a separate sample of plug with ISOD for each type of socket-outlet, with each sample being inserted into and withdrawn from the socket-outlet at a rate of 6 insertions and 6 withdrawals per minute, the speed of travel of the plug being approximately 150mm/s	After 5000 insertions and withdrawals completed, socket outlets show no damage that would impair further use. Plugs show no damage and suit for the dimensional requirements according to clause 12.2. The shutters of the socket-outlets operate satisfactorily and socket contacts safety shielded.	P
22.2	Resistance to heat		P
	After 1h in heating cabinet at 80°C and a force of 20 N through the jaws no damage shown	Test performed on plug portion (including ISOD) and max. 0.5mm measured after 1 hour. Limit: 2mm	P

BS 1363-1			
Clause	Requirement + Test	Result - Remark	Verdict
23	Resistance of insulating material to abnormal heat and fire		P
	Insulating material not unduly affected by abnormal heat and by fire	Glow wire test performed on enclosure with: 650°C. All enclosure material have been considered.	P
	Insulating material not unduly affected by abnormal heat and by fire	Glow wire test performed on plug portion (including ISOD) with: 750°C. All enclosure material have been considered.	P

BS 1363-1

Clause	Requirement + Test	Result - Remark	Verdict
--------	--------------------	-----------------	---------

PLUG PORTION DIMENSIONS

<u>Linear Dimensions (mm)</u>		<u>Measurement</u>		<u>Limit</u>	
*A		25.07	25.07	25.370 max.	
*B		30.77	30.77	34.6 max.	
*C		Tested by gauge	Tested by gauge	15 min.	
D		9.95	9.95	9.5 min.	
*E	L -> E	11.11	11.12	11.05 - 11.18	
	N -> E	11.10	11.11		
*F	L -> E	22.29	22.28	22.10 - 22.36	
	N -> E	22.29	22.28		
G1		6.27	6.28	6.22 - 6.48	
G2		6.28	6.28	6.22 - 6.48	
H		3.99	4.00	3.90 - 4.05	
*I		22.88	22.84	22.23 - 23.23	
J		1.53	1.51	1.35 - 1.85	
K		8.00	8.02	7.80 - 8.05	7.75 - 8.05 For ISOD
L	line	9.38	9.41	9.5 max.	
	neutral	9.38	9.41		
M	line	8.86	8.87	9.2 max.	
	neutral	8.86	8.87		
N (sleeve)	line	4.03	4.02	3.90 - 4.05	
	neutral	4.02	4.02		
O	line	18.05	18.06	17.20 - 18.20	
	neutral	18.07	18.06		
P	Line	1.51	1.52	1.35 - 1.85	
	neutral	1.52	1.52		
	earth	1.54	1.53		
Q (metal)	line	3.95	3.96	3.90 - 4.05	
	neutral	3.96	3.97		
	earth	4.00	4.01		
R	Line	1.68	1.69	1.2 - 2.0	
	neutral	1.67	1.69		
	earth	1.68	1.72		
S	line	1.44	1.48	1.35 - 1.85	
	neutral	1.44	1.48		

BS 1363-1			
Clause	Requirement + Test	Result - Remark	Verdict

*Remark: all these dimensions were checked by the relevant gauge (based on BS1363: Part 1:1995 Figure 5)

Angular Dimensions (°)		Measurement		Limits
01		60°	60°	58° - 62°
02	line	68°	68°	60° - 80°
	neutral	68°	68°	
	earth	71°	71°	
03	line	60°	60°	58° - 62°
	neutral	60°	60°	

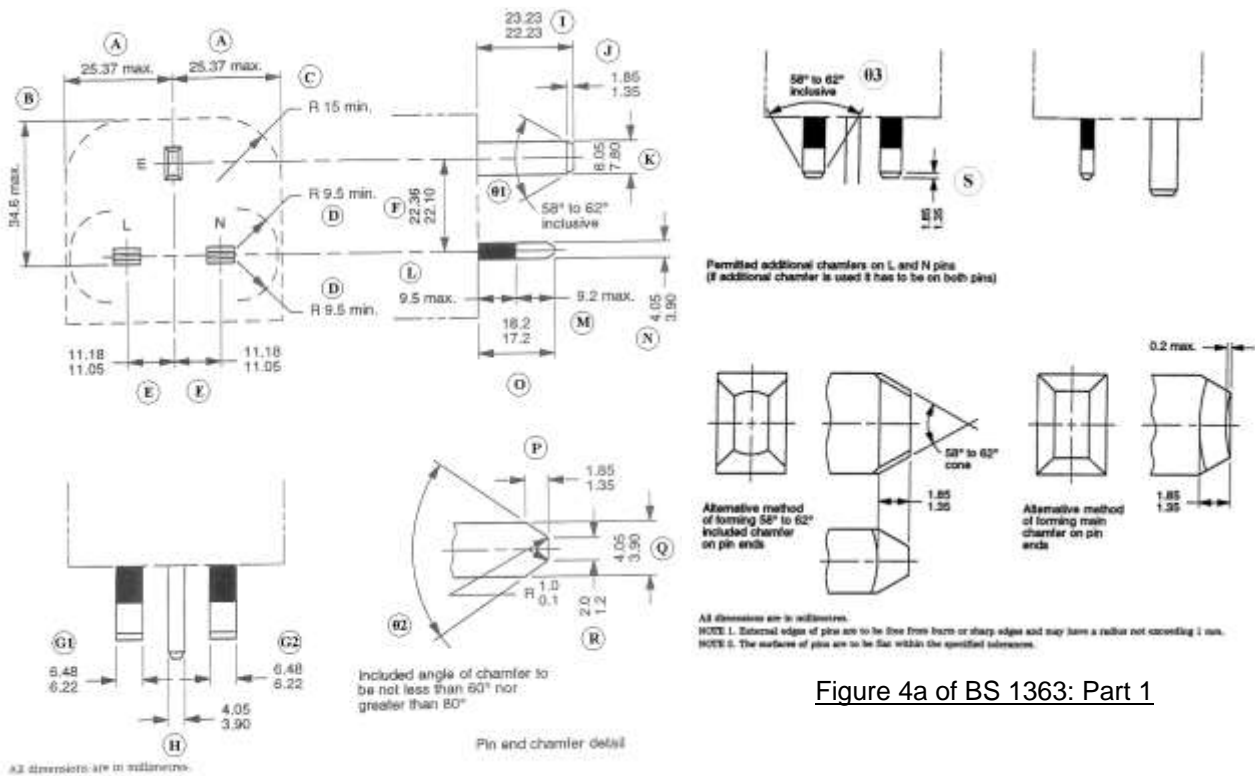

Figure 4a of BS 1363: Part 1

* Remark: all these dimensions were checked by the relevant gauge (based on BS1363: Part 1:1995 Figure 5)

Plug Portion Dimensions (Solid insulated shutter opening device ISOD)

Linear Dimensions (mm)		Sample A	Limit
T		8.00	7.75 - 8.05
U		4.03	3.90 - 4.05
V	E -> L	0.125	0.15 max

BS 1363-1			
Clause	Requirement + Test	Result - Remark	Verdict

	E -> N	0.125	0.15 max
W	E -> top	0.124	0.15 max
	E -> L & N	0.124	0.15 max

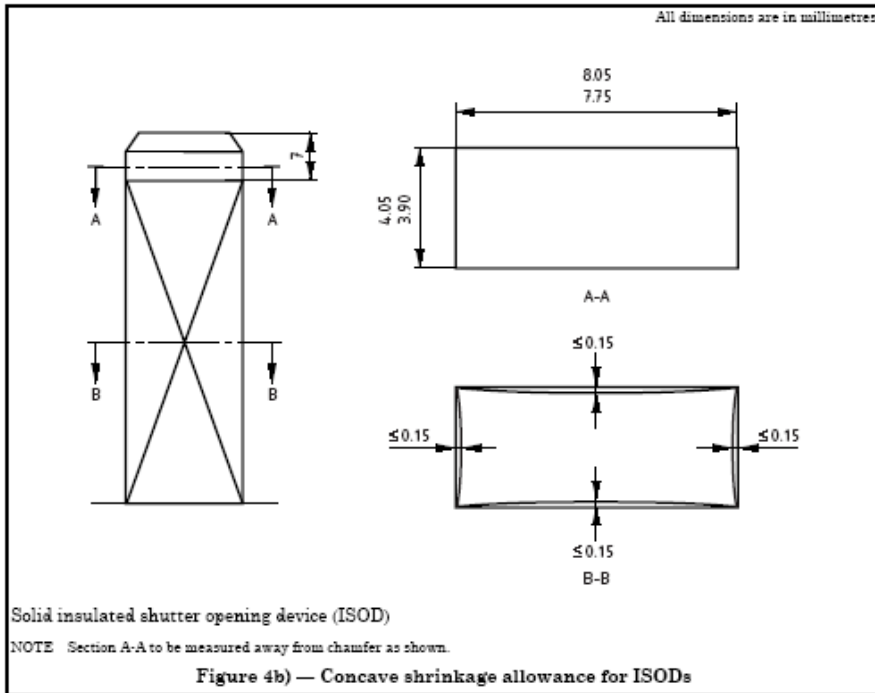

Figure 4b of BS 1363: Part 1

Appendix 1: Photo document

Photo 1
Description: Overall view

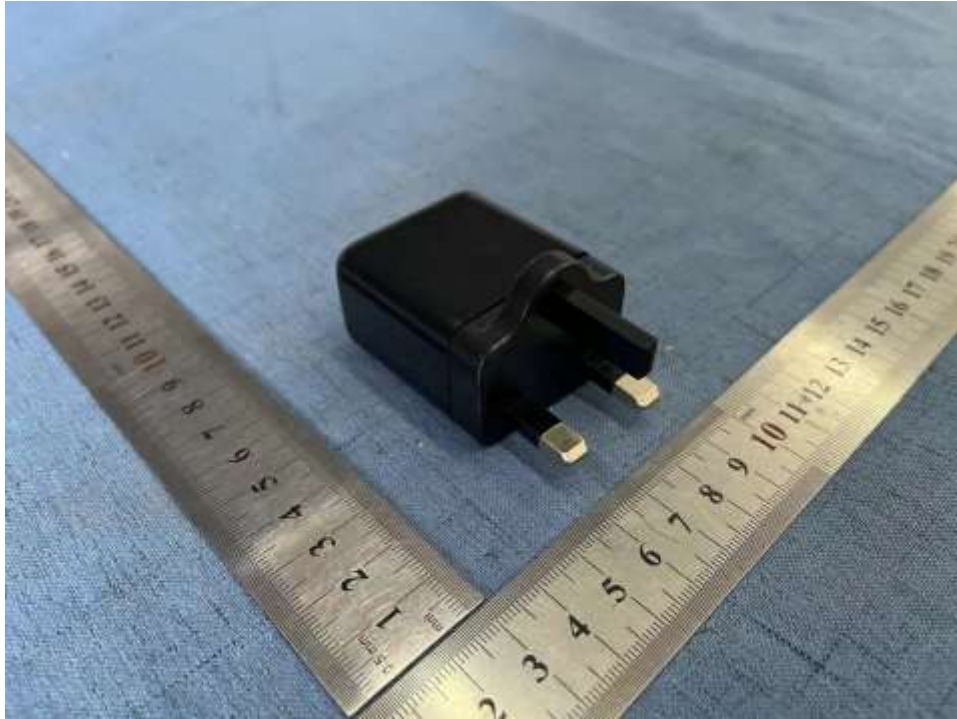

Photo 2
Description: Overall view



Photo 3
Description: Overall view

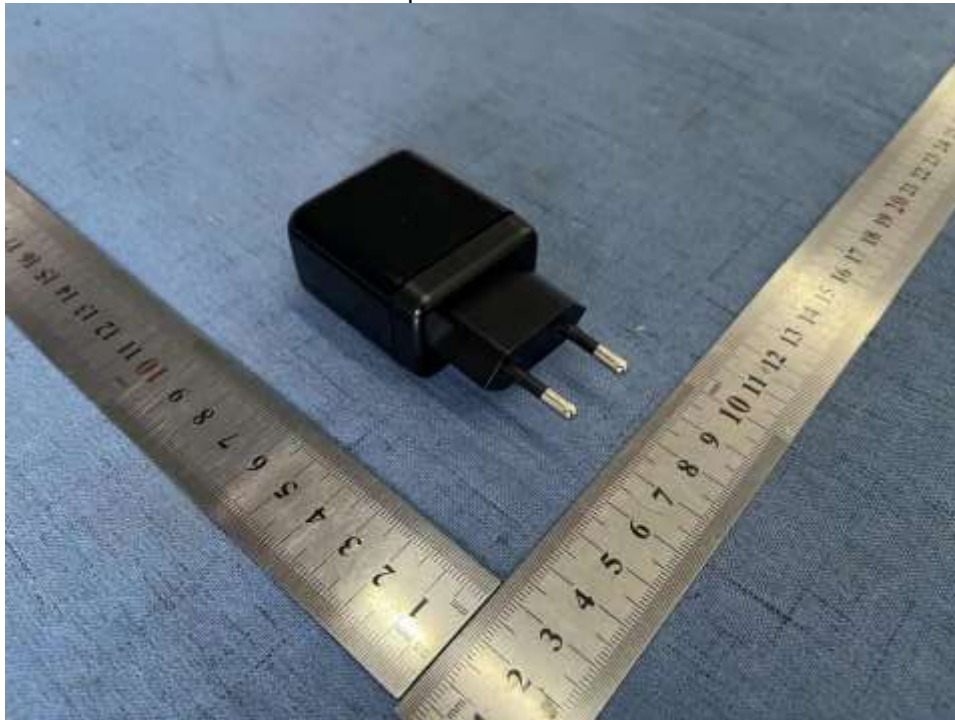

Photo 4
Description: Overall view

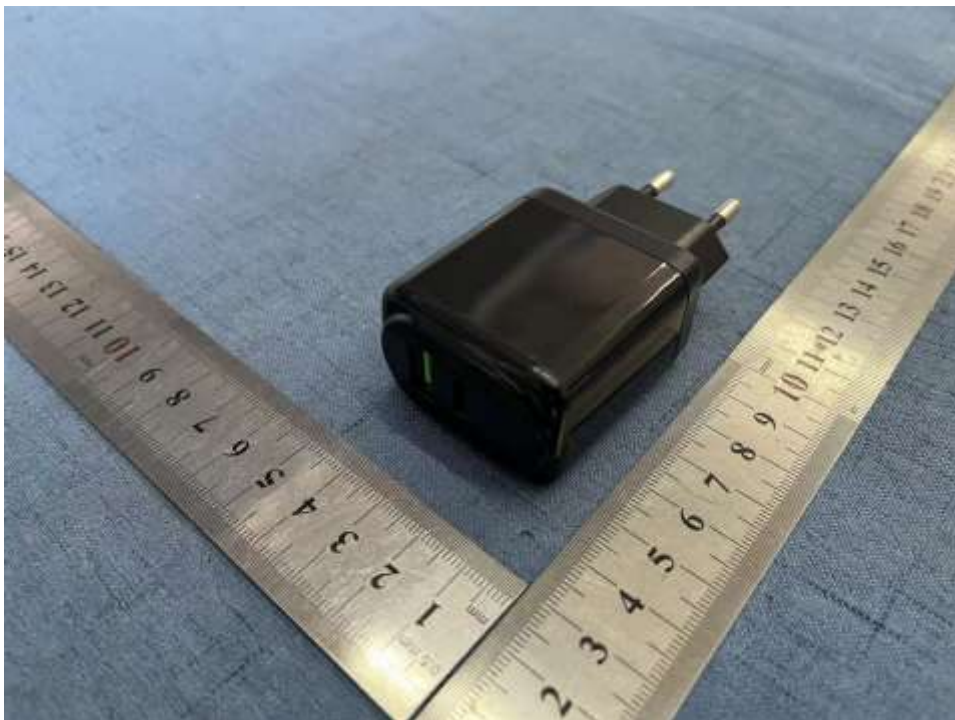

Photo 5
Description: Inside view



Photo 6
Description: Component side view of PCB

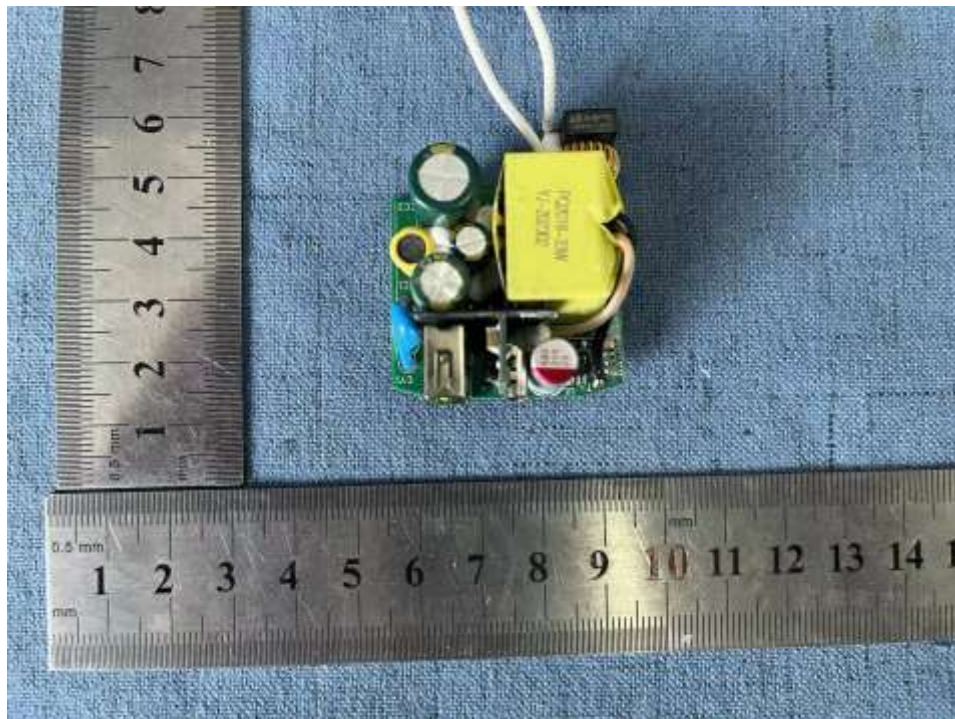
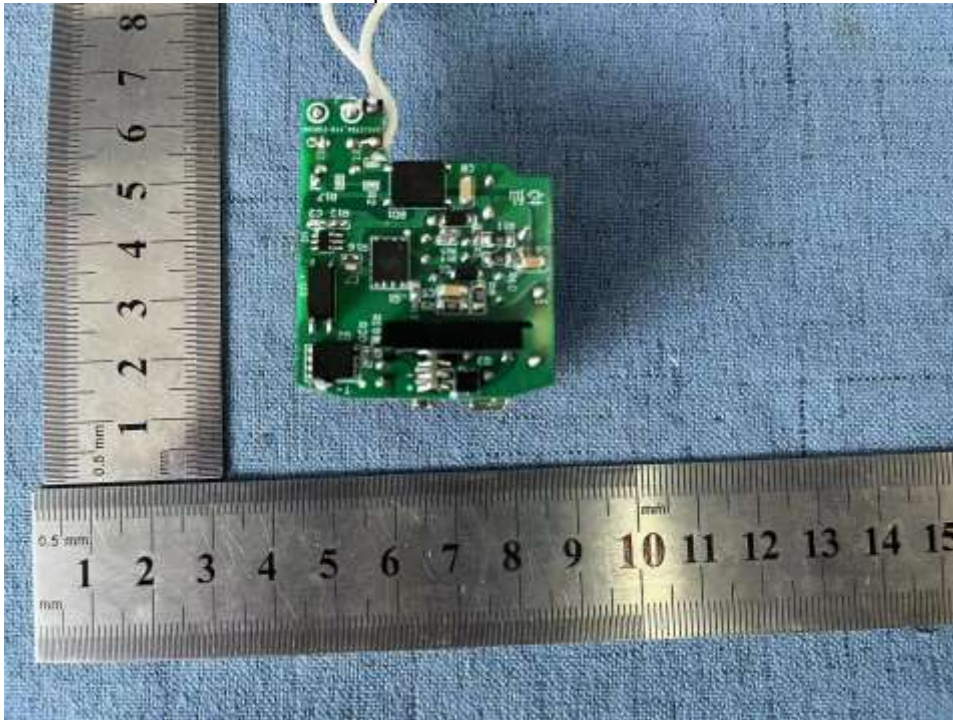

Photo 7

Description: Trace side view of PCB



--- End of Report ---