

peerless-AV[®]

ACC-SB2

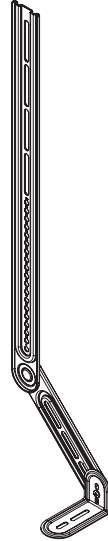

US Only

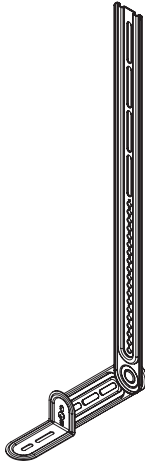
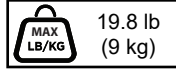

EMEA Only



| | |
|-----|------------------------------------------------------------------------------------------------------------|
| ENG | Scan QR code for manufacturer specific device installation. |
| ESP | Escanee el código de respuesta rápida para la instalación del dispositivo específico del fabricante. |
| FRN | Balayer le code QR pour obtenir les instructions d'installation spécifiques au constructeur de l'appareil. |
| DEU | Den QR-Code scannen, um die herstellerepezifische Installationsanleitung für die Vorrichtung aufzurufen. |
| NEL | Scan de QR-code voor de fabrikantsspecifieke installatie. |
| ITL | Inquadrare il codice QR per le istruzioni su come installare lo specifico dispositivo. |
| ČES | Naskenujte QR kód pro instalaci konkrétního zařízení výrobce. |
| SLK | Naskenujte QR kód pre inštaláciu konkrétneho zariadenia výrobcu. |
| POR | Digitalize o código QR para a instalação do dispositivo específico do fabricante. |
| TÜR | Üreticiye özel cihaz kurulumu için QR kodunu tarayın. |



▲ WARNING

ENG - Before installing make sure the supporting surface will support the combined load of the equipment and hardware. Screws must be tightly secured. Do not overtighten screws or damage can occur and product may fail. Never exceed the Maximum Load Capacity. Always use an assistant or mechanical lifting equipment to safely lift and position equipment. This product is intended for indoor use only. Use of this product outdoors could lead to product failure or personal injury. Be careful not to pinch fingers when operating the mount. For support please call customer care at 1-800-865-2112.

▲ ADVERTENCIA

ESP - Antes de instalarlo, asegúrese de que la superficie de apoyo sostendrá la carga combinada del equipo y los fijadores. Los tornillos se tienen que fijar firmemente. No apriete los tornillos en exceso, ya que se pueden dañar y el producto podría fallar. Nunca exceda la Capacidad Máxima de Carga. Siempre cuente con la ayuda de un asistente o utilice un equipo mecánico de izar para levantar y colocar el equipo con más seguridad. Este producto está diseñado para uso en interiores solamente. Utilizar este producto en exteriores podría causar fallas del producto o lesiones a individuos. Tenga cuidado de no pincharse los dedos cuando extienda y recoja el soporte contra la pared. Si necesita ayuda, por favor, llame a Servicio al Cliente de Peerless al 1-800-865-2112.

▲ ADVERTISSEMENT

FRN - Avant de procéder à l'installation, assurez-vous que la surface de support peut soutenir la charge totale de l'équipement ainsi que des pièces de fixation. Les vis doivent être serrées au maximum. Ne serrez pas trop les vis pour éviter tout risque d'endommager le produit et de causer sa défaillance. Ne dépassez jamais la capacité de charge maximale. Pour lever et positionner l'équipement en toute sécurité, faites-vous toujours aider par une autre personne ou utilisez un dispositif de levage mécanique. Ce produit est conçu uniquement pour un usage intérieur. L'utilisation de ce produit à l'extérieur peut causer une défaillance du produit ou des blessures corporelles. Prenez garde à ne pas vous pincer les doigts en dépliant le support et en le repliant contre le mur. Pour toute assistance, veuillez contacter le service à la clientèle au 1-800-865-2112.

▲ ACHTUNG

DEU - Vergewissern Sie sich vor der Anbringung, dass die tragende Fläche das Gesamtgewicht der Geräte und der Befestigungsteile tragen kann. Die Schrauben müssen sicher angezogen werden. Ziehen Sie die Schrauben nicht zu fest an, damit es nicht zu Beschädigungen und Versagen des Produkts kommt. Die maximale Tragfähigkeit darf niemals überschritten werden. Ziehen Sie immer eine zusätzliche Person heran oder verwenden Sie mechanische Hebegeräte, um Geräte sicher zu heben und zu positionieren. Dieses Produkt ist nur für den Gebrauch innerhalb von Gebäuden bestimmt. Eine Verwendung dieses Produkts im Freien kann zu Produktausfall oder Personenschaden führen. Achten Sie darauf, dass Sie die Finger nicht einklemmen, wenn der Halter von der Wand weg gezogen bzw. zu ihr hin geschoben wird. Falls Sie Unterstützung benötigen, wenden Sie sich bitte an den Kundendienst unter der Telefonnummer +1-800-865-2112 (innerhalb der USA).

▲ WAARSCHUWING

NEL - Vóór de installatie dient u zich ervan te overtuigen dat het dragende oppervlak het totaalgewicht van de apparatuur en de hardware aankan. Alle schroeven moeten stevig vastzitten. Draai de schroeven niet te strak aan, want dit zou kunnen resulteren in schade en/of falen van het product. Het maximale draagvermogen mag nooit worden overschreden. Belangrijke veiligheidstip: zorg er tijdens het optillen en op zijn plaats zetten van de apparatuur altijd voor dat u een helper of een mechanische hefinrichting ter beschikking hebt. Dit product is uitsluitend bedoeld voor gebruik binnenshuis. Als dit product buitenshuis wordt gebruikt, zijn falen van het product en letsel bij personen mogelijk. Let er tijdens het in- en uitvouwen van de bevestiging op dat uw vingers niet beklemd raken. Voor ondersteuning kunt u terecht bij de afdeling Klantenzorg op 1-800-865-2112 (in de VS).

▲ AVVERTENZA

ITL - Prima di iniziare l'installazione, verificare che la superficie destinata all'installazione sia in grado di sostenere il carico totale del prodotto e dei dispositivi di fissaggio. Le viti devono essere serrate in modo stretto. Non stringere eccessivamente le viti, altrimenti si rischiano danni o il prodotto potrebbe non funzionare correttamente. Non superare mai la capacità massima di carico. Per sollevare e posizionare in modo sicuro l'unità, farsi aiutare da una persona o usare un sollevatore meccanico. Questo prodotto deve essere usato solamente in ambienti interni. Usato all'esterno, il prodotto potrebbe guastarsi o causare infortuni alla persona. Nell'aprire e chiudere il supporto dalla parete, stare attenti a non schiacciarsi le dita. Per ogni chiarimento, telefonare al Servizio Clienti al numero verde 1-800-865-2112.

▲ VÝSTRAHA

ČEŠ - Před instalací se ujistěte, že podpurný povrch udrží součet zatížení zařízení a hardwaru. Šrouby je třeba dotáhnout napevno. Nedotahujte šrouby nadměrně, jinak by mohlo dojít ke škodám a selhání funkce výrobku. Nikdy nepřekračujte maximální kapacitu zatížení. Vždy používejte pomoc druhé osoby nebo mechanického zdvižného zařízení tak, abyste dokázali zařízení bezpečně zvednout a umístit. Tento výrobek je určen pouze pro použití ve vnitřních prostorech. Používání tohoto výrobku venku by mohlo vést k selhání funkce výrobku nebo ke zranění osob. Buďte opatrní a při otevírání a zavírání držáku ze zdi si nepřískřípnete prsty. Pro podporu prosím volejte zákaznickou linku na čísle 1-800-865-2112.

▲ VÝSTRAHA

SLK - Pred inštaláciou sa ubezpečte, že podpurný povrch udrží súčet zaťaženia zariadenia a hardwaru. Skrutky treba pevne dotiahnuť. Nedotahujte skrutky nadmerne, inak by mohlo dôjsť ku škodám a zlyhaniu funkcie výrobku. Nikdy neprekračujte maximálnu kapacitu zaťaženia. Vždy používajte pomoc druhej osoby alebo mechanického zdvíhacieho zariadenia tak, aby ste dokázali zariadenie bezpečne zodvihnúť a umiestniť. Tento výrobok je určený iba na použitie vo vnútorných priestoroch. Používanie tohoto výrobku vonku by mohlo viesť k zlyhaniu funkcie výrobku alebo k zraneniu osôb. Buďte opatrní a pri otváraní a zatváraní držiaka zo steny si nepřiškripnete prsty. Pre podporu prosím volajte zákaznickú linku na čísle 1-800-865-2112.

▲ AVISO

POR - Antes de instalar, certifique-se de que a superfície de apoio suporta a carga combinado do equipamento e das ferragens. Os parafusos devem ser bem apertados. Não aperte demasiado os parafusos, pois podem ocorrer danos ou falhas do produto. Nunca exceder a Capacidade de carga máxima. Utilize sempre um assistente ou equipamento de elevação mecânica para elevar e posicionar o equipamento em segurança. Este produto destina-se a utilização exclusivamente em zonas interiores. A utilização deste produto em espaços exteriores poderá conduzir à falha do produto ou ferimentos pessoais. Deve ser exercida atenção para não prender os dedos ao abrir e fechar o suporte da parede. Para obter assistência, contacte a equipa de apoio ao cliente através do número 1-800-865-2112.

▲ UYARI

TÜR - Montaja başlamadan önce taşıyıcı yüzeyin hem takacağınız ekipmanı hem e aksami birlikte taşıyacağından emin olun. Vidalar sağlam bir şekilde sıkıştırılmalıdır. Vidaları aşırı sıkıştırırsanız vidalara hasar verebilirsiniz ve ürün düşebilir. Asla Azami Taşıma Kapasitesini aşmayın. Her zaman için ekipmanı doğru şekilde kaldırmak ve yerine koymak için ya başka birinden yardım alın ya da mekanik kaldırma donanımından faydalanın. Bu ürün sadece iç mekânlarda kullanılmak üzere imal edilmiştir. Bu ürünün dış mekânda kullanılması ürün arızasına veya yaralanmaya neden olabilir. Kaideyi duvarda açarken veya kaparken parmaklarınızı sıkıştırmamaya devam edin. Destek için lütfen müşteri hizmetlerini arayın: 1-800-865-2112.

| | |
|-----|-----------|
| ENG | Symbols |
| ESP | Símbolos |
| FRN | Symboles |
| DEU | Symbole |
| NEL | Symbolen |
| ITL | Simboli |
| ČES | Symboly |
| SLK | Symboly |
| POR | Símbolos |
| TÜR | Semboller |

| | | | | | | | | | | | | | | | | | | | | | |
|----------------------------------------------------------------------------------|----------------------------------------------------------------------------------------------------------------------------------------------------------------------------------------------------------------------------------------------------------------------------------------------------------------------------------------------------------------------------------------------------------------------------------------------------------------------------------------------------------------|-----|----------------|-----|--------------------|-----|-----------------------|-----|----------------|-----|---------------------|-----|-------------------|-----|-----------------|-----|-----------------|-----|--------------|-----|--------------|
|  | <table border="1"> <tr><td>ENG</td><td>WARNING</td></tr> <tr><td>ESP</td><td>ADVERTENCIA</td></tr> <tr><td>FRN</td><td>ADVERTISSEMENT</td></tr> <tr><td>DEU</td><td>ACHTUNG</td></tr> <tr><td>NEL</td><td>WAARSCHUWING</td></tr> <tr><td>ITL</td><td>AVVERTENZA</td></tr> <tr><td>ČES</td><td>VÝSTRAHA</td></tr> <tr><td>SLK</td><td>VÝSTRAHA</td></tr> <tr><td>POR</td><td>AVISO</td></tr> <tr><td>TÜR</td><td>UYARI</td></tr> </table> | ENG | WARNING | ESP | ADVERTENCIA | FRN | ADVERTISSEMENT | DEU | ACHTUNG | NEL | WAARSCHUWING | ITL | AVVERTENZA | ČES | VÝSTRAHA | SLK | VÝSTRAHA | POR | AVISO | TÜR | UYARI |
| ENG | WARNING | | | | | | | | | | | | | | | | | | | | |
| ESP | ADVERTENCIA | | | | | | | | | | | | | | | | | | | | |
| FRN | ADVERTISSEMENT | | | | | | | | | | | | | | | | | | | | |
| DEU | ACHTUNG | | | | | | | | | | | | | | | | | | | | |
| NEL | WAARSCHUWING | | | | | | | | | | | | | | | | | | | | |
| ITL | AVVERTENZA | | | | | | | | | | | | | | | | | | | | |
| ČES | VÝSTRAHA | | | | | | | | | | | | | | | | | | | | |
| SLK | VÝSTRAHA | | | | | | | | | | | | | | | | | | | | |
| POR | AVISO | | | | | | | | | | | | | | | | | | | | |
| TÜR | UYARI | | | | | | | | | | | | | | | | | | | | |

| | | | | | | | | | | | | | | | | | | | | | |
|----------------------------------------------------------------------------------|-----------------------------------------------------------------------------------------------------------------------------------------------------------------------------------------------------------------------------------------------------------------------------------------------------------------------------------------------------------------------------------------------------------------------------------------------------------------------------------------------------------------------------|-----|---------------|-----|-----------------------|-----|-------------------|-----|---------------------|-----|--------------------|-----|---------------|-----|--------------------|-----|--------------------|-----|----------------------|-----|---------------|
|  | <table border="1"> <tr><td>ENG</td><td>Skip to step.</td></tr> <tr><td>ESP</td><td>Continúe con el paso.</td></tr> <tr><td>FRN</td><td>Passez à l'étape.</td></tr> <tr><td>DEU</td><td>Weiter mit Schritt.</td></tr> <tr><td>NEL</td><td>Ga door naar stap.</td></tr> <tr><td>ITL</td><td>Vai al passo.</td></tr> <tr><td>ČES</td><td>Přeskočte na krok.</td></tr> <tr><td>SLK</td><td>Preskočte na krok.</td></tr> <tr><td>POR</td><td>Saltar para o passo.</td></tr> <tr><td>TÜR</td><td>Su adima geç.</td></tr> </table> | ENG | Skip to step. | ESP | Continúe con el paso. | FRN | Passez à l'étape. | DEU | Weiter mit Schritt. | NEL | Ga door naar stap. | ITL | Vai al passo. | ČES | Přeskočte na krok. | SLK | Preskočte na krok. | POR | Saltar para o passo. | TÜR | Su adima geç. |
| ENG | Skip to step. | | | | | | | | | | | | | | | | | | | | |
| ESP | Continúe con el paso. | | | | | | | | | | | | | | | | | | | | |
| FRN | Passez à l'étape. | | | | | | | | | | | | | | | | | | | | |
| DEU | Weiter mit Schritt. | | | | | | | | | | | | | | | | | | | | |
| NEL | Ga door naar stap. | | | | | | | | | | | | | | | | | | | | |
| ITL | Vai al passo. | | | | | | | | | | | | | | | | | | | | |
| ČES | Přeskočte na krok. | | | | | | | | | | | | | | | | | | | | |
| SLK | Preskočte na krok. | | | | | | | | | | | | | | | | | | | | |
| POR | Saltar para o passo. | | | | | | | | | | | | | | | | | | | | |
| TÜR | Su adima geç. | | | | | | | | | | | | | | | | | | | | |

| | | | | | | | | | | | | | | | | | | | | | |
|----------------------------------------------------------------------------------|------------------------------------------------------------------------------------------------------------------------------------------------------------------------------------------------------------------------------------------------------------------------------------------------------------------------------------------------------------------------------------------------------------------------------------------------------------------------------------------------------------------------------------------------------------------------------------------------------------------------------------------------------------------------------------------------------------------------------------------------------------------------------------------------------------------------------------------------------------------------------------------------------------------------------------------------------------------------------------------------------------------------------------------------------------------------------------------------|-----|---------------------------------------------------------|-----|----------------------------------------------------------------------------------------|-----|--------------------------------------------------------------------------------|-----|----------------------------------------------------------------------------------------|-----|------------------------------------------------------------------------------------------|-----|---------------------------------------------------------|-----|-------------------------------------------------------------------|-----|-----------------------------------------------------------------|-----|---------------------------------------------------------------------------------------|-----|----------------------------------------------------------|
|  | <table border="1"> <tr><td>ENG</td><td>Screws must get at least three full turns and fit snug.</td></tr> <tr><td>ESP</td><td>Los tornillos tienen que dar, por lo menos, tres vueltas completas y quedar ajustados.</td></tr> <tr><td>FRN</td><td>Il faut effectuer au moins trois tours de vis complets et bien serrer les vis.</td></tr> <tr><td>DEU</td><td>Schrauben sind mindestens drei volle Umdrehungen einzudrehen und müssen fest anliegen.</td></tr> <tr><td>NEL</td><td>De schroeven moeten ten minste drie hele slagen worden aangedraaid en stevig vastzitten.</td></tr> <tr><td>ITL</td><td>Girare tre volte le viti che devono risultare aderenti.</td></tr> <tr><td>ČES</td><td>Šrouby se musí otočit minimálně tři plně otáčky a plně dosednout.</td></tr> <tr><td>SLK</td><td>Skrutky sa musia otočiť aspoň tri celé otáčky a tesne dosadnúť.</td></tr> <tr><td>POR</td><td>Os parafusos devem completar, no mínimo, três voltas completas e ajustar-se no local.</td></tr> <tr><td>TÜR</td><td>Vidalari en az üç tam dönüş yapmalı ve sıkı oturmalıdır.</td></tr> </table> | ENG | Screws must get at least three full turns and fit snug. | ESP | Los tornillos tienen que dar, por lo menos, tres vueltas completas y quedar ajustados. | FRN | Il faut effectuer au moins trois tours de vis complets et bien serrer les vis. | DEU | Schrauben sind mindestens drei volle Umdrehungen einzudrehen und müssen fest anliegen. | NEL | De schroeven moeten ten minste drie hele slagen worden aangedraaid en stevig vastzitten. | ITL | Girare tre volte le viti che devono risultare aderenti. | ČES | Šrouby se musí otočit minimálně tři plně otáčky a plně dosednout. | SLK | Skrutky sa musia otočiť aspoň tri celé otáčky a tesne dosadnúť. | POR | Os parafusos devem completar, no mínimo, três voltas completas e ajustar-se no local. | TÜR | Vidalari en az üç tam dönüş yapmalı ve sıkı oturmalıdır. |
| ENG | Screws must get at least three full turns and fit snug. | | | | | | | | | | | | | | | | | | | | |
| ESP | Los tornillos tienen que dar, por lo menos, tres vueltas completas y quedar ajustados. | | | | | | | | | | | | | | | | | | | | |
| FRN | Il faut effectuer au moins trois tours de vis complets et bien serrer les vis. | | | | | | | | | | | | | | | | | | | | |
| DEU | Schrauben sind mindestens drei volle Umdrehungen einzudrehen und müssen fest anliegen. | | | | | | | | | | | | | | | | | | | | |
| NEL | De schroeven moeten ten minste drie hele slagen worden aangedraaid en stevig vastzitten. | | | | | | | | | | | | | | | | | | | | |
| ITL | Girare tre volte le viti che devono risultare aderenti. | | | | | | | | | | | | | | | | | | | | |
| ČES | Šrouby se musí otočit minimálně tři plně otáčky a plně dosednout. | | | | | | | | | | | | | | | | | | | | |
| SLK | Skrutky sa musia otočiť aspoň tri celé otáčky a tesne dosadnúť. | | | | | | | | | | | | | | | | | | | | |
| POR | Os parafusos devem completar, no mínimo, três voltas completas e ajustar-se no local. | | | | | | | | | | | | | | | | | | | | |
| TÜR | Vidalari en az üç tam dönüş yapmalı ve sıkı oturmalıdır. | | | | | | | | | | | | | | | | | | | | |

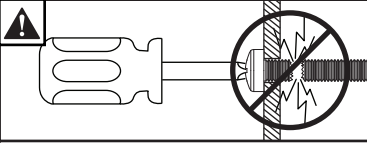
| | | | | | | | | | | | | | | | | | | | | | |
|----------------------------------------------------------------------------------|-----------------------------------------------------------------------------------------------------------------------------------------------------------------------------------------------------------------------------------------------------------------------------------------------------------------------------------------------------------------------------------------------------------------------------------------------------------------------------------------------------------------------------------------------------------------------------------------------------------------------------------------------------------------------------------------|-----|----------------------------|-----|----------------------------------|-----|-----------------------------|-----|--------------------------------------------|-----|---------------------------------------|-----|-------------------------------|-----|---------------------------------|-----|----------------------------------|-----|-------------------------------------|-----|-------------------------------------|
|  | <table border="1"> <tr><td>ENG</td><td>Do not overtighten screws.</td></tr> <tr><td>ESP</td><td>No apriete de más los tornillos.</td></tr> <tr><td>FRN</td><td>Ne pas trop serrer les vis.</td></tr> <tr><td>DEU</td><td>Ziehen Sie die Schrauben nicht zu fest an.</td></tr> <tr><td>NEL</td><td>Draai de schroeven niet te strak aan.</td></tr> <tr><td>ITL</td><td>Non stringere troppo le viti.</td></tr> <tr><td>ČES</td><td>Šrouby neutahujte příliš silně.</td></tr> <tr><td>SLK</td><td>Skrutky neutahujte príliš silno.</td></tr> <tr><td>POR</td><td>Não apertar demasiado os parafusos.</td></tr> <tr><td>TÜR</td><td>Vidalari gereğinden fazla sıkmayın.</td></tr> </table> | ENG | Do not overtighten screws. | ESP | No apriete de más los tornillos. | FRN | Ne pas trop serrer les vis. | DEU | Ziehen Sie die Schrauben nicht zu fest an. | NEL | Draai de schroeven niet te strak aan. | ITL | Non stringere troppo le viti. | ČES | Šrouby neutahujte příliš silně. | SLK | Skrutky neutahujte príliš silno. | POR | Não apertar demasiado os parafusos. | TÜR | Vidalari gereğinden fazla sıkmayın. |
| ENG | Do not overtighten screws. | | | | | | | | | | | | | | | | | | | | |
| ESP | No apriete de más los tornillos. | | | | | | | | | | | | | | | | | | | | |
| FRN | Ne pas trop serrer les vis. | | | | | | | | | | | | | | | | | | | | |
| DEU | Ziehen Sie die Schrauben nicht zu fest an. | | | | | | | | | | | | | | | | | | | | |
| NEL | Draai de schroeven niet te strak aan. | | | | | | | | | | | | | | | | | | | | |
| ITL | Non stringere troppo le viti. | | | | | | | | | | | | | | | | | | | | |
| ČES | Šrouby neutahujte příliš silně. | | | | | | | | | | | | | | | | | | | | |
| SLK | Skrutky neutahujte príliš silno. | | | | | | | | | | | | | | | | | | | | |
| POR | Não apertar demasiado os parafusos. | | | | | | | | | | | | | | | | | | | | |
| TÜR | Vidalari gereğinden fazla sıkmayın. | | | | | | | | | | | | | | | | | | | | |

| | |
|-----|----------------------------------------------|
| ENG | Tools Needed for Assembly. |
| ESP | Herramientas necesarias para el ensamblaje. |
| FRN | Outils nécessaires au montage. |
| DEU | Für den Zusammenbau erforderliche Werkzeuge. |
| NEL | Voor montage benodigd gereedschap. |
| ITL | Attrezzi necessari per l'assemblaggio. |
| ČES | Nástroje potřebné k montáži. |
| SLK | Nástroje potrebné na montáž. |
| POR | Ferramentas necessárias para a montagem. |
| TÜR | Montaj İçin Gereklİ Aletler. |

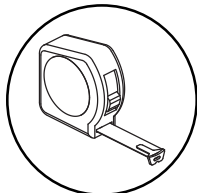
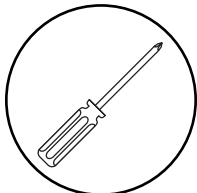
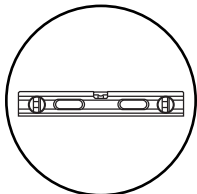

ENG To properly tighten screws: Tighten until screw head makes contact, then tighten another 1/2 turn. Do not overtighten screws.

ESP Apriete adecuado de los tornillos: Apriete hasta que la cabeza del tornillo haga contacto y luego apriete otra 1/2 vuelta. No apriete de más los tornillos.

FRN Pour bien serrer les vis : Serrez jusqu'à ce que la tête de la vis entre en contact, puis serrez encore d'un 1/2 tour. Ne serrez pas trop les vis.

DEU Korrektes Festziehen der Schrauben: Ziehen Sie die Schrauben fest, bis der Schraubenkopf Kontakt hat, und dann um eine weitere 1/2 Umdrehung. Ziehen Sie die Schrauben nicht zu fest an.

NEL Ga als volgt te werk om de schroeven naar behoren aan te draaien: Draai de schroef aan totdat de kop het oppervlak raakt; maak daarna nog een halve slag. Draai de schroeven niet te strak aan.

ITL Per stringere correttamente le viti: stringere fino a quando la testa della vite fa contatto, quindi stringere di un altro 1/2 giro. Non stringere eccessivamente.

ČES Správné utážení šroubů: Utahujte, dokud se šroub nedostane do kontaktu, poté utáhněte ještě půl otočky. Šrouby neutahujte příliš silně.

SLK Správne utiahnutie skrutiek: Utahujte, kým sa skrutka nedostane do kontaktu, potom utiahnite ešte pol otočky. Skrutky neutahujte príliš silno.

POR Para apertar correctamente os parafusos: aperte até que a cabeça do parafuso estabeleça contacto e, em seguida, aperte mais 1/2 volta. Não aperte demasiado os parafusos.

TÜR Vidaları doğru bir şekilde sıkılmak için: Vida başı temas edene kadar döndürün, sonra yarım tur daha döndürün. Vidaları gereğinden fazla sıkılmayın.

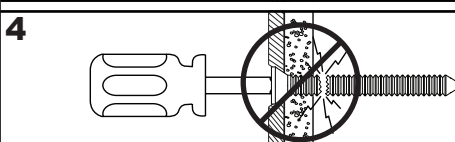
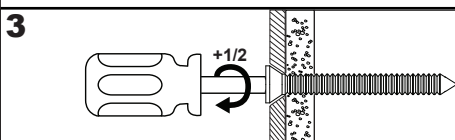
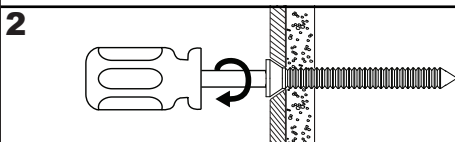
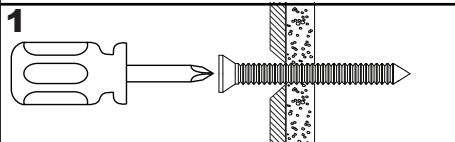

| | |
|-----|-------------------------------------------------------------------------------------------------------|
| ENG | Parts (Before beginning, make sure you have all parts shown below). |
| ESP | Piezas (antes de iniciar, asegúrese de tener todas las piezas siguientes). |
| FRN | Pièces (avant de commencer, assurez-vous d'avoir toutes les pièces illustrées ci-dessous). |
| DEU | Teile (Achten Sie vor Beginn der Arbeiten darauf, dass alle unten abgebildeten Teile vorhanden sind). |
| NEL | Onderdelen (hoort u zich ervan te overtuigen dat u alle onderdelen hebt, die hieronder te zien zijn). |
| ITL | Parti (prima di iniziare, accertarsi di disporre tutte le parti sotto indicate). |
| ČES | Díly (předtím, než začnete, připravte si všechny díly zobrazené níže). |
| SLK | Diely (predtým, ako začnete, pripravte si všetky diely zobrazené nižšie). |
| POR | Peças (antes de iniciar, certifique-se de que tem todas as peças apresentadas em baixo). |
| TÜR | Parçalar (Başlamadan önce, aşağıda gösterilen bütün parçaların elinizde olduğundan emin olun). |

| Parts List | |
|---------------------------------|-----|
| Description | Qty |
| A bracket | 2 |
| B extension arm | 2 |
| C M4 x 16mm phillips screw | 2 |
| D M5 x 16mm phillips screw | 2 |
| E M6 x 16mm phillips screw | 2 |
| F M5/M6 washer | 4 |
| G key hole bolt | 2 |
| H M6 wing nut | 2 |
| I M6 x 12mm phillips screw | 2 |
| J M6 nut | 2 |
| K M6 x 16mm phillips screw | 4 |
| L M6 x 25mm phillips screw | 4 |
| M M8 x 25mm phillips screw | 4 |
| N M8 x 45mm phillips screw | 4 |
| O M6 washer | 4 |
| P 2.5mm spacer | 4 |
| Q M8 x 4mm spacer | 2 |
| R M8 x 10mm spacer | 4 |
| S 1/4-20 x 5/16" phillips screw | 2 |
| T 1/4-20 x 1/2" phillips screw | 2 |

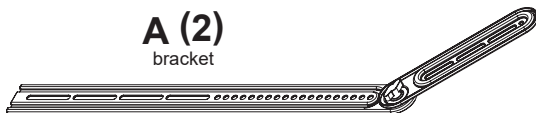

B (2)
extension arm



C (2)
M4 x 16mm

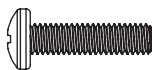

D (2)
M5 x 16mm



E (2)
M6 x 16mm

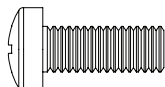

F (4)
M5/M6 washer

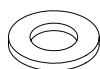

G (2)
key hole bolt

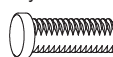

H (2)
M6 wing nut



I (2)
M6 x 12mm

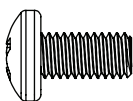

J (2)
M6 nut

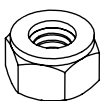

K (4)
M6 x 16mm

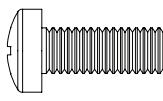

L (4)
M6 x 25mm

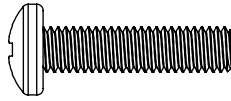

M (4)
M8 x 25mm

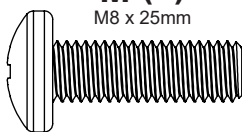

N (4)
M8 x 45mm

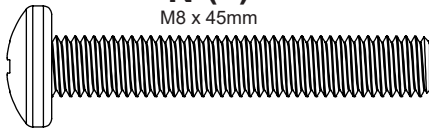

O (4)
M6 washer

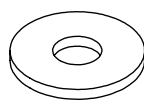

P (4)
2.5mm spacer



Q (2)
M8 x 4mm spacer

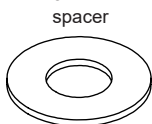

R (4)
M8 x 10mm spacer

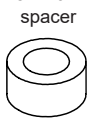

S (2)
1/4-20 x 5/16"

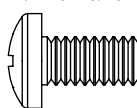

T (2)
1/4-20 x 1/2"

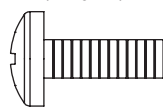

1

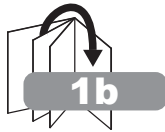
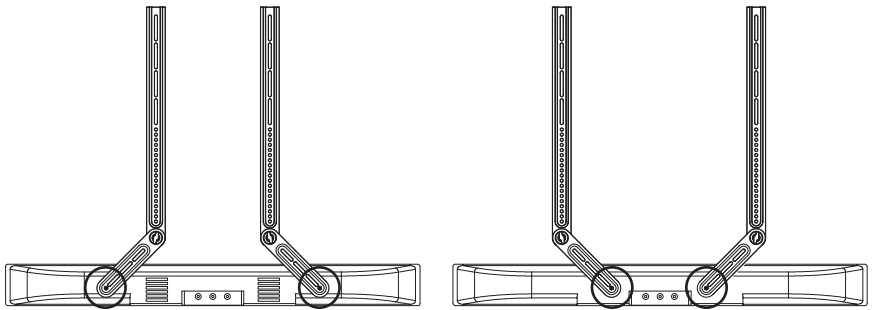
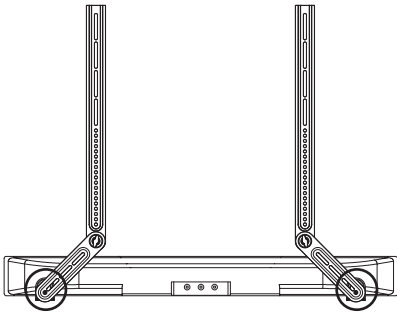

1a-1

x2

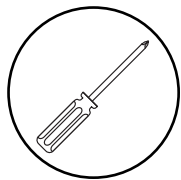
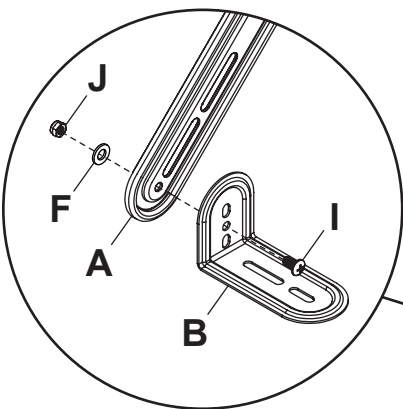

1a-2

| | |
|-----|--------------------------|
| ENG | Not included. |
| ESP | No incluidos. |
| FRN | Non compris. |
| DEU | Nicht inbegriffen. |
| NEL | Niet bijgeleverd. |
| ITL | Non incluso. |
| ČES | Není součástí balení. |
| SLK | Nie je súčasťou balenia. |
| POR | Não incluído. |
| TÜR | Dahil değildir. |

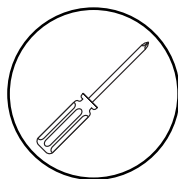
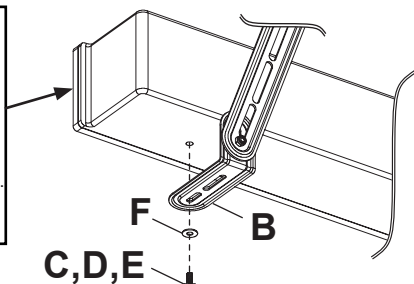

1b

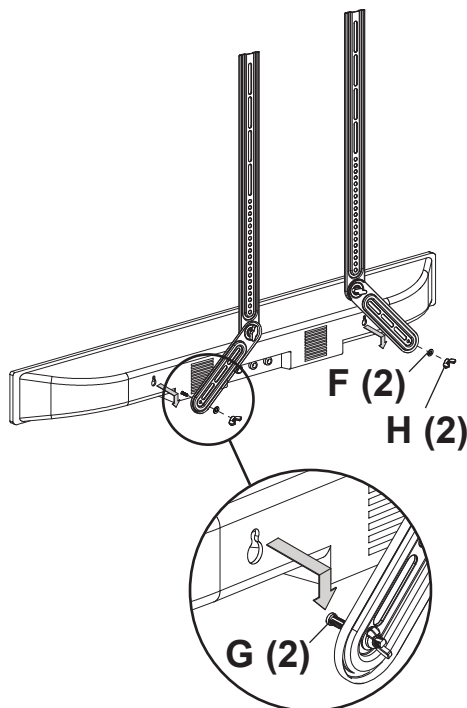
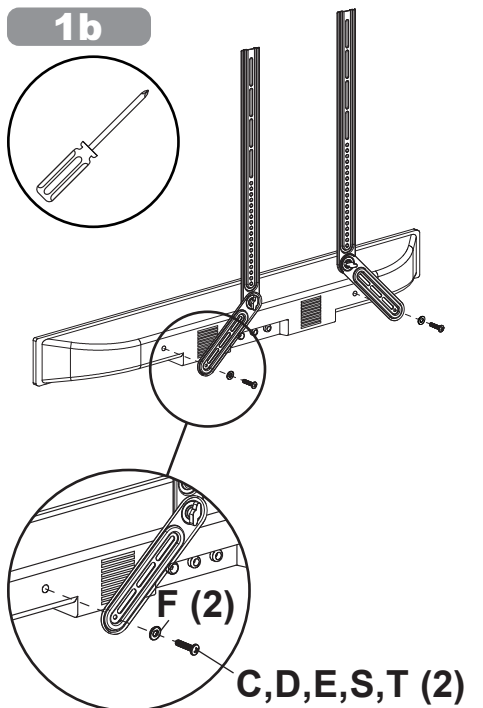
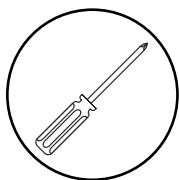

2

| | |
|-----|-------------------------------------------------------------------------------------------------------------------|
| ENG | Center brackets horizontally on back of screen. |
| ESP | Centralice los soportes horizontalmente en la parte trasera de la pantalla. |
| FRN | Centrez les fixations à l'horizontale au dos de l'écran. |
| DEU | Zentrieren Sie die Halterungen horizontal auf der Rückseite des Bildschirms. |
| NEL | Centreer de beugels horizontaal op de achterkant van het scherm.centra le staffe verticalmente sul dello schermo. |
| ITL | Centrare le staffe orizzontalmente sul retro dello schermo. |
| ČES | Vodorovně vycentrujte konzoly na zadní straně obrazovky. |
| SLK | Vodorovne vycentrujte konzoly na zadnej strane obrazovky. |
| POR | Centralizar os suportes horizontalmente na parte traseira do ecrã. |
| TÜR | Askı aparatlarını ekranın arkasında yatay olarak ortalayın. |

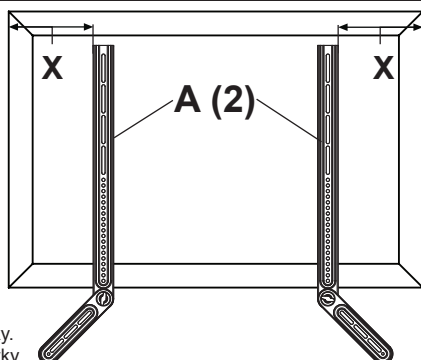



- ENG** Use of spacers is optional.
ESP Uso de espaciadores opcional.
FRN Facultatif utilisation d'entretoises.
DEU Optional Verwendung von Abstandhaltern.
NEL Facultatief gebruik van tussenringen.
ITL Uso opzionale di distanziatori.
ČES Volitelné použití rozpěr.
SLK Voltiteľné použitie rozpierok.
POR Opcional utilize espaçadores.
TÜR Ayırıcıların isteğe bağlı kullanımı.

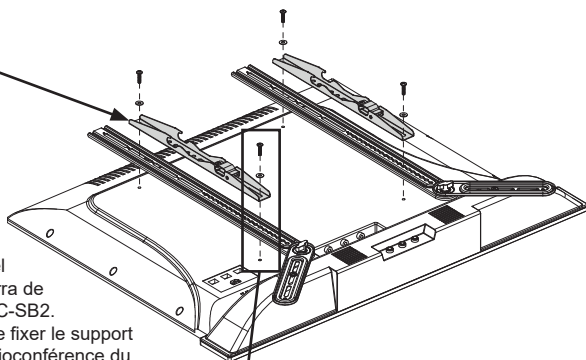
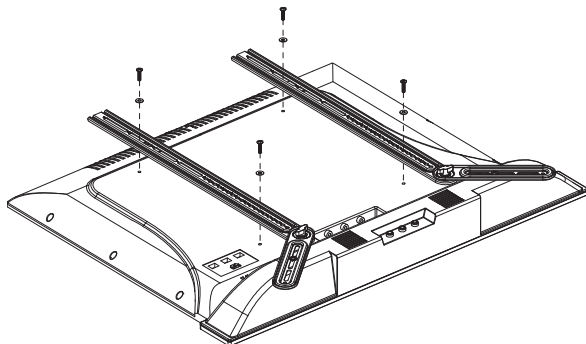
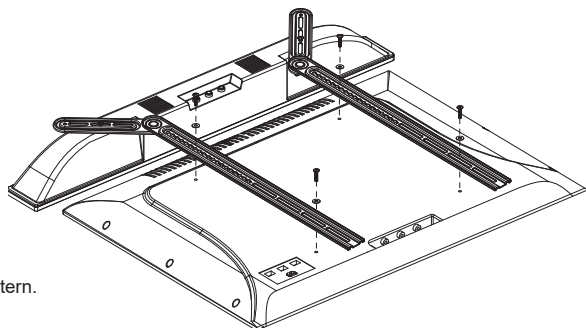

- ENG** Sold separately.
ESP Vendidos por separado.
FRN Vendu séparément.
DEU Separat verkauft.
NEL Apart verkocht.
ITL Venduto a parte.
ČES Prodává se samostatně.
SLK Predáva sa samostatne.
POR Vendido em separado.
TÜR Ayırıcı satılır.

- ENG** In some cases it is necessary to affix the wall mount bracket that comes with the manufacturers video conferencing bar to the ACC-SB2.
ESP En algunos casos, es necesario fijar el soporte de pared que viene con la barra de videoconferencia del fabricante al ACC-SB2.
FRN Dans certains cas, il est nécessaire de fixer le support mural qui accompagne la barre de visioconférence du constructeur sur l'ACC-SB2.
DEU In manchen Fällen muss die im Lieferumfang der Videokonferenzleiste des jeweiligen Herstellers enthaltene Wandmontagehalterung am ACC-SB2 befestigt werden.
NEL In sommige gevallen is het noodzakelijk om de wandbeugel die wordt meegeleverd bij de videovergaderingsbalk van de fabrikant aan de ACC-SB2 te bevestigen.
ITL In alcuni casi è necessario fissare all'ACC-SB2 la staffa per montaggio a parete acclusa al modulo per videoconferenza.
ČES V některých případech je nutné k ACC-SB2 připevnit držák pro montáž na stěnu, který je součástí výrobce dodané videokonferenční lišty.
SLK V niektorých prípadoch je nutné k ACC-SB2 pripievnit držiak pre montáž na stenu, ktorý je súčasťou výrobcu dodanej videokonferenčnej lišty.
POR Em alguns casos, é necessário fixar o suporte de montagem na parede que acompanha a barra de videoconferência do fabricante no ACC-SB2.
TÜR Bazı durumlarda üreticinin video konferans çubuğu ile birlikte gelen duvara montaj braketini ACC-SB2'ye takmak gerekir.

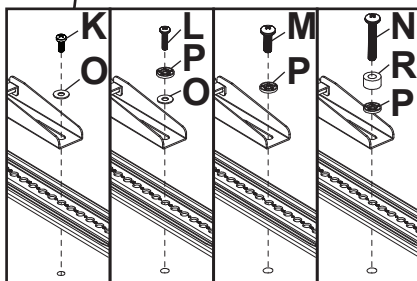

| | |
|-----|-------------------------------------------------------|
| ENG | This page intentionally left blank. |
| ESP | Página en blanco. |
| FRN | Cette page a été laissée en blanc intentionnellement. |
| DEU | Diese Seite wurde absichtlich freigelassen. |
| NEL | Deze pagina is met opzet blanco gelaten. |
| ITL | Pagina lasciata intenzionalmente vuota. |
| ČEŠ | Tato strana je záměrně prázdná. |
| SLK | Táto strana je zámerne prázdná. |
| POR | Esta página foi intencionalmente deixada em branco. |
| TÜR | Bu sayfa özellikle boş bırakılmıştır. |

| | |
|-----|-------------------------------------------------------|
| ENG | This page intentionally left blank. |
| ESP | Página en blanco. |
| FRN | Cette page a été laissée en blanc intentionnellement. |
| DEU | Diese Seite wurde absichtlich freigelassen. |
| NEL | Deze pagina is met opzet blanco gelaten. |
| ITL | Pagina lasciata intenzionalmente vuota. |
| ČEŠ | Tato strana je záměrně prázdná. |
| SLK | Táto strana je zámerne prázdna. |
| POR | Esta página foi intencionalmente deixada em branco. |
| TÜR | Bu sayfa özellikle boş bırakılmıştır. |

ENG Warranty
ITL Garanzia

ESP Garantía
ČES Záruka

FRN Garantie
SLK Záruka

DEU Garantie
POR Garantia

NEL Garantie
TÜR Garanti

www.peerless-av.com/warranty • www.peerless-av.com • www.peerless-av.com/patents

peerless-AV[®]

Peerless-AV
2300 White Oak Circle
Aurora, IL 60502, USA
info@peerless-av.com

(800) 865-2112
(630) 375-5100

Peerless-AV EMEA
Unit 2, Curo Park
Frogmore, St. Albans,
Hertfordshire, AL2 2DD
United Kingdom

+44 (0) 1923 200 100

Peerless-AV B.V.
Papendorpseweg 75
3528 BJ Utrecht
The Netherlands

+31 (0) 70 770 8037

Peerless-AV Latin America
Av. de las Industrias 413
Parque Industrial Escobedo
General Escobedo N.L.,
México 66062

+52 (81) 8384-8300